

Blowers & Fans

Centrifugal Blower

透浦式鼓風機



CHUAN FAN



台灣產品新型專利第 339596 • 345887 • 205327 • 142704 • 375137 • M425944 號
中國產品新型專利第 1243826 號

用途

- 印刷機械
- 燃燒機
- 塑膠押出機、吹袋機淋膜機
- 製果機械
- 集塵機
- 環境機械
- 熱風發生機
- 粉粒體輸送
- 廚房機械
- 木工機械
- 乾燥機
- 焚化爐
- 恆溫箱
- 機械冷卻
- 一般送風



CX 透浦式



HTB 透浦多段式



TB 透浦式

特點

- 高壓·大風量·低噪音·輕量化
- 採用鋁合金材質，大幅降低重量，達到輕量化的目的。
- 馬達為 I.E.C.設計 (1 HP以上)，全閉外扇型鋁框馬達，特殊軸心設計，可適合長時間使用。
- 特殊葉片設計，壓力高·風量大·噪音低·壽命長。
- 特殊風量調節風門，風量控制穩定性高，操作容易 (CX.TB.HTB適用)。
- 樣式種類齊全·庫存多·交貨迅速。

Applications

- Printing Machines
- Burning Machines
- Plastic Extruders, Laminating, Film Making Machines
- Uniform Temperature Equipment
- Household Machines
- Dust Collectors
- Textile Machines
- Pollution Machines
- Hot Air Blowers
- Dryers Machines
- Incinerators
- Machinery for the Food and Beverage Industries
- Machinery for Cooling
- Woodworking Machines
- Grain elevators



低壓鑄造機
Low Pressure Casting Machines



重力壓鑄機
Gravity Die Casting Machines



壓鑄機
Die Casting Machines



CNC 加工區
CNC Vertical Lache



馬達定子繞線
Stator coil & Wedge inserter



馬達組裝與自動測試
Motor Assembly & Test Line

Features

- High pressur • Larger flow • Light weight
- Aluminum alloy material was Widespread be use, offer light products.
- I. E. C. Designed motor (1HP UP), Squirrel Cage Induction Motors & specially designated shaft can satisfy long-time-continue operation.
- Professional impeller designed, high pressure, larger flow • low noise • and long life.
- Special air-flow-adjust designs offer stable flows and easily control.
- Full range styles and sufficiently finished products of each model make quickly delivery be possible.

透浦式鼓風機 Turbo Blower (Centrifugal Blower)

at 50/60HZ

型式 Type	相數 Phase	功率 Output (KW)	電壓 Voltage (V)	電流 Current (A)	最大靜壓 (吐出) Pressure (Max.) (kpa)	最大風量 (吐出) Air Flow (Max.) (m ³ /min)	吸入/吐出 口徑 In/Out Let (mm)	噪音 Noise Level (dB)	重量 Weight (Kg)
CX-65	1~ 3~	0.2	220 220/380	1.5 1.1/0.9	0.7/11	4.5/5.3	IN 100 OUT 65	50/62	6
CX-75SA	1~ 3~	0.4	220 220/380	2.5 1.9/1.2	1.1/1.6	7/8	IN 100 OUT 75	56/70	9
CX-75A	1~ 3~	0.74	220 220/380	5 3/1.9	1.7/2.4	13/15	IN 125 OUT 100	64/80	16
CX-100A	3~	1.5	220/380	5.5/3.5	2/3	20/23	IN 125 OUT 100	74/90	26
CX-125A	3~	2.2	220/380	8/5	2.4/3.7	32/37	IN 252 OUT 125	76/95	36
CX-150A	3~	3.7	220/380	13/7.5	3.2/4.4	46/53	IN 252 OUT 150	80/100	56

性能表 Characteristic curves

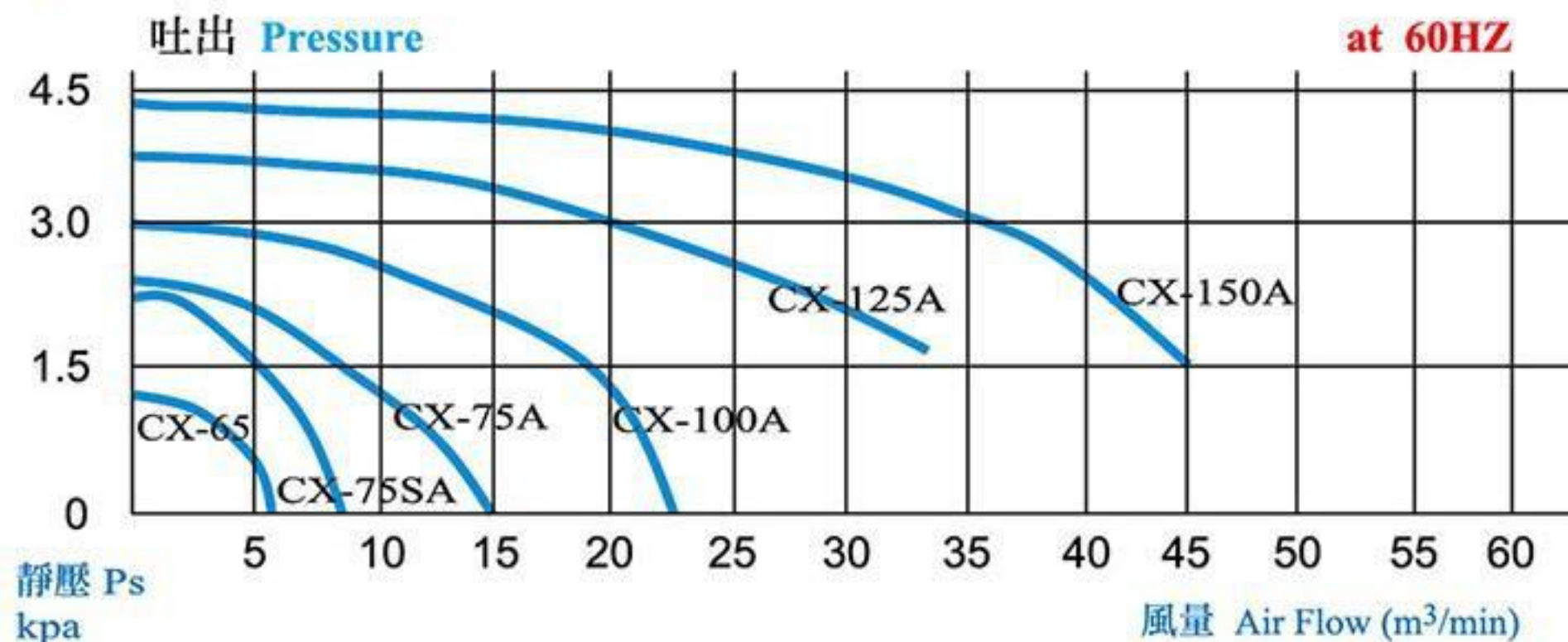
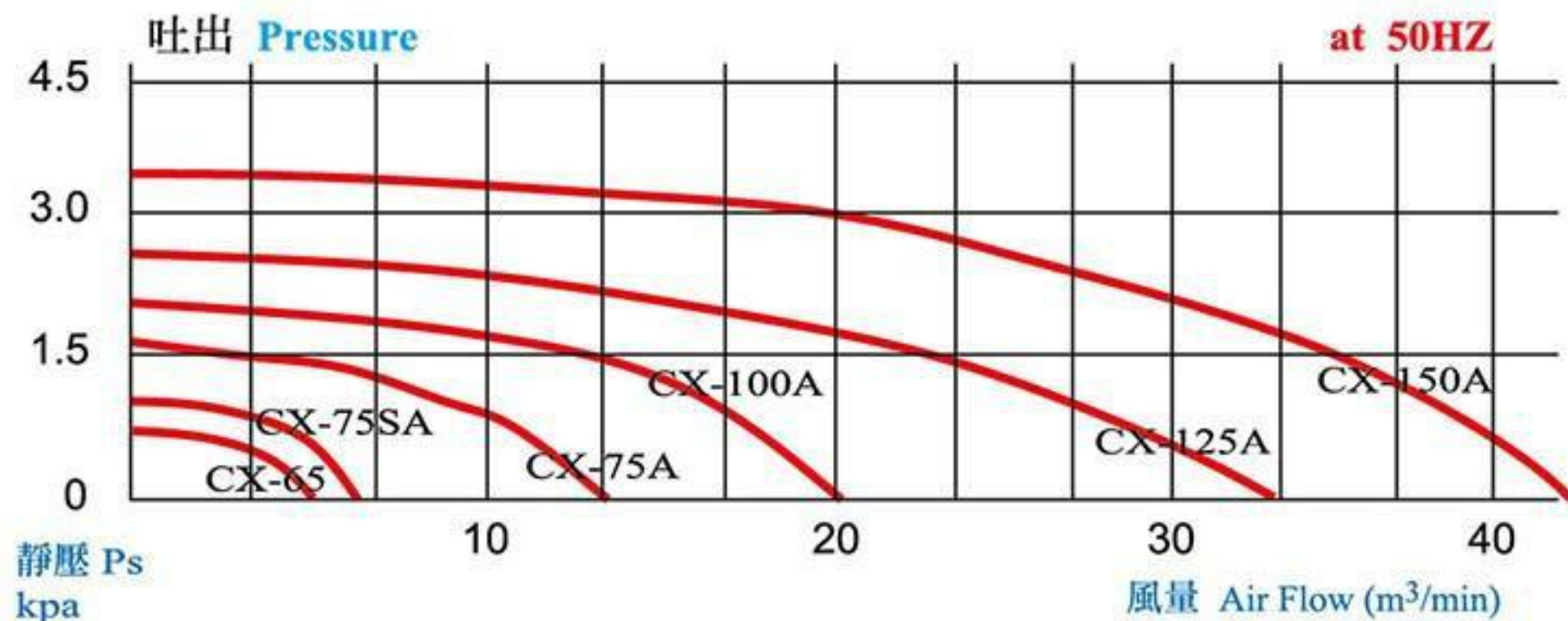

透浦式鼓風機 Turbo Blower (Centrifugal Blower)

尺寸圖 Dimension (mm)

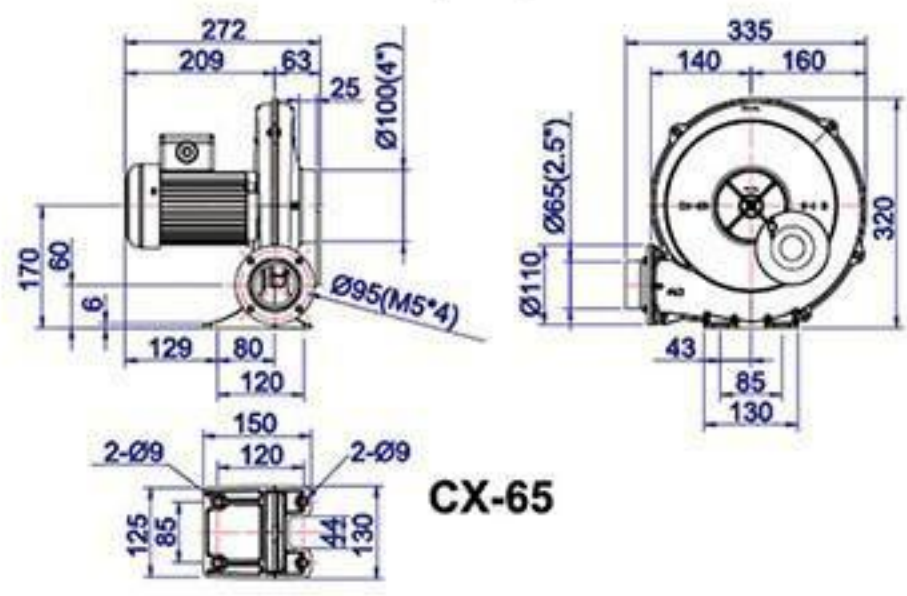

CX-65

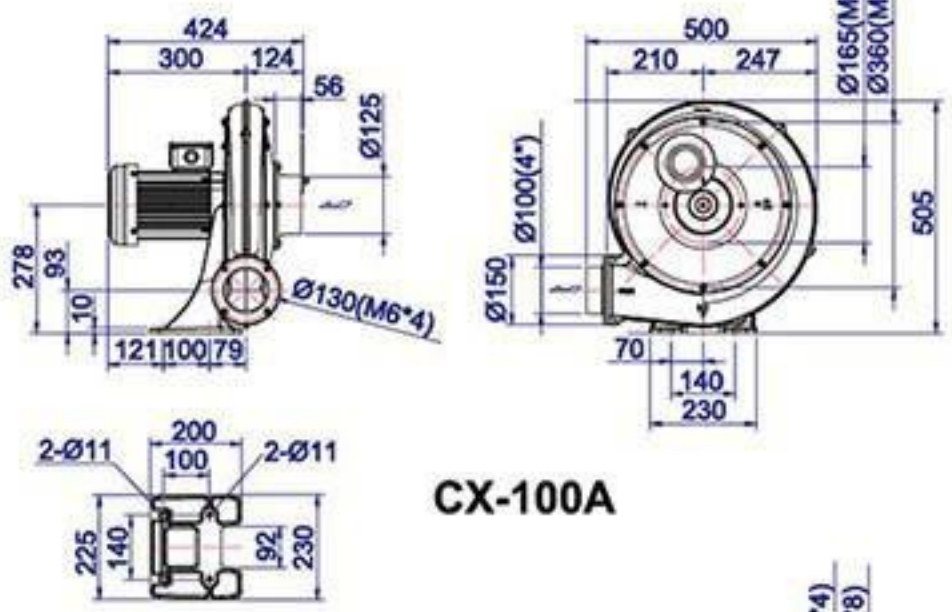

CX-100A

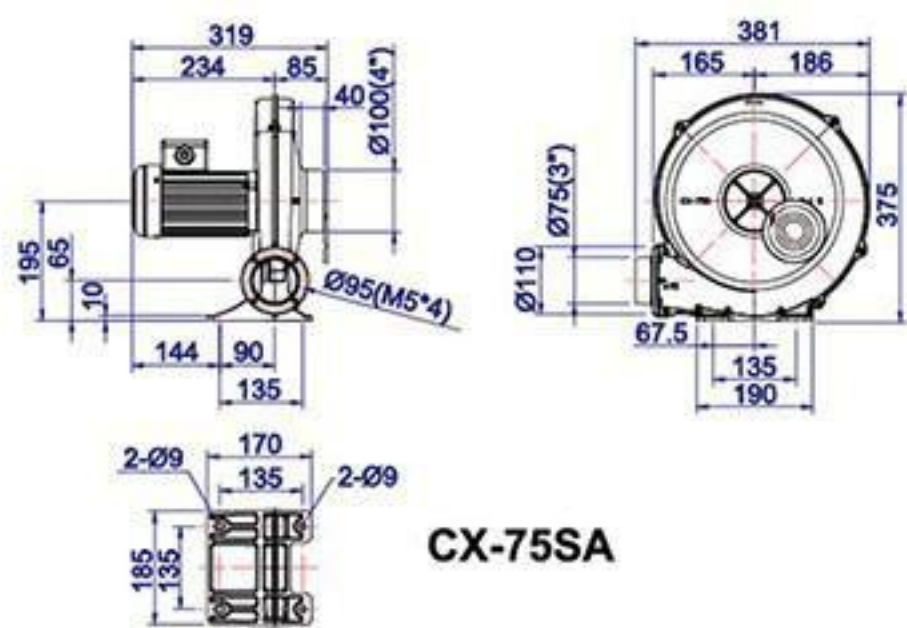

CX-75SA

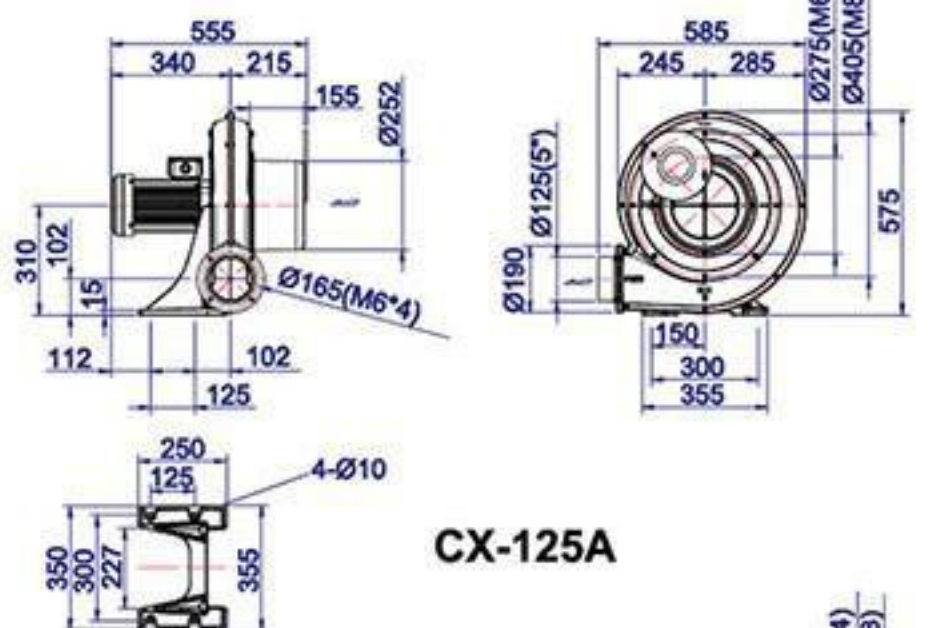

CX-125A

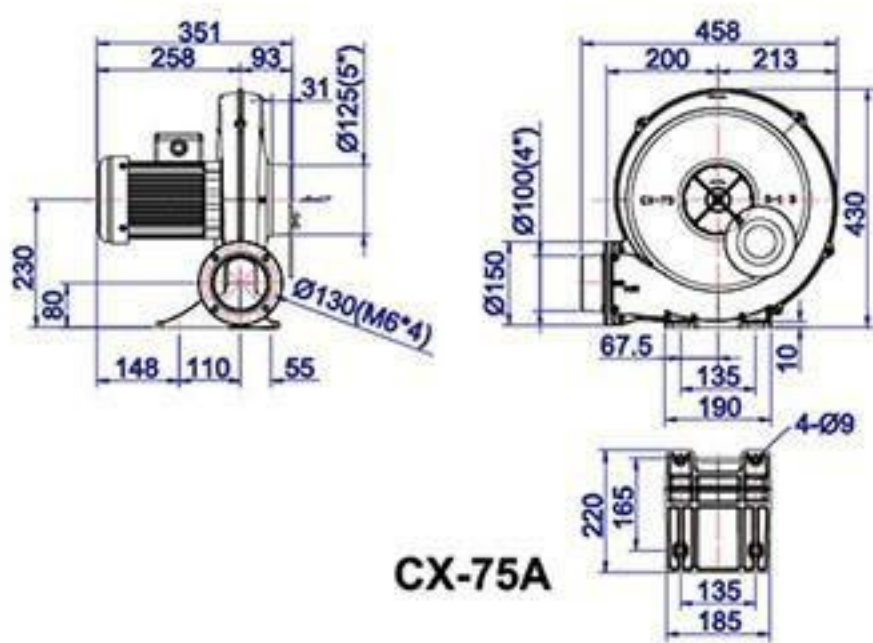

CX-75A

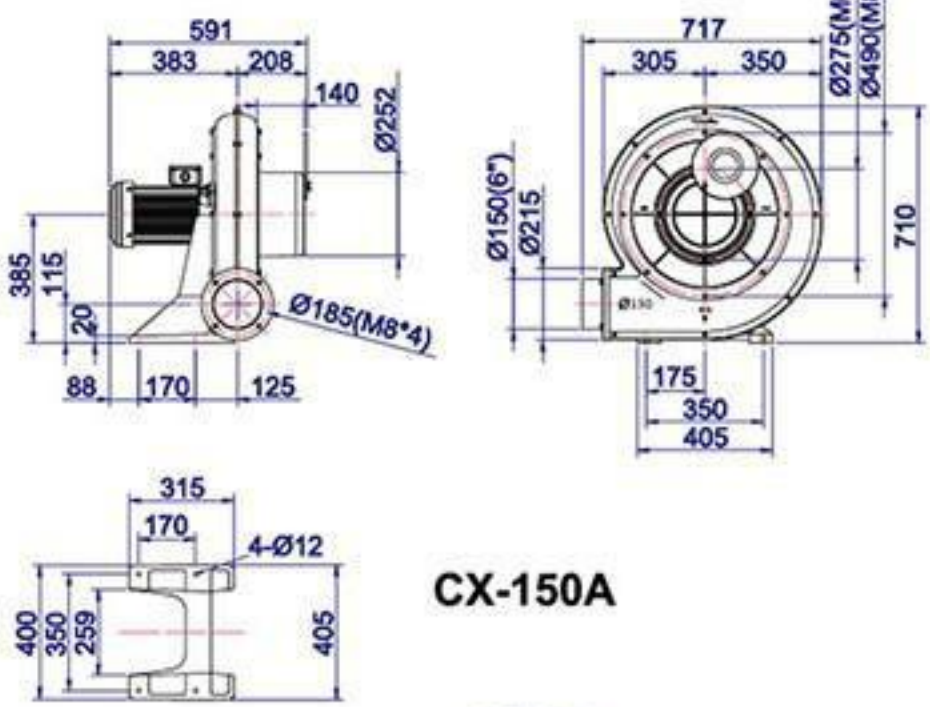

CX-150A



CX-75SA



CX-125A

透浦式鼓風機 Turbo Blower (Centrifugal Blower)

at 50/60HZ

型式 Type	相數 Phase	功率 Output (KW)	電壓 Voltage (V)	電流 Current (A)	最大靜壓 (吐出) Pressure (Max.) (kpa)	最大風量 (吐出) Air Flow (Max.) (m ³ /min)	出口 口徑 Out Let	噪音 Noise Level (dB)	重量 Weight (Kg)
TB100-1	3~	0.75	220 380	3 1.8	1.3/2.1	18/22	100mm	70/80	22
TB100-2	3~	1.5	220 380	5.5 3.5	2/3	20/25	100mm	70/85	26
TB125-3	3~	2.2	220 380	8 5	2.4/3.6	33/39	125mm	80/90	35
TB150-5	3~	3.7	220 380	13 7.5	3.8/5.3	48/53	150mm	90/95	57
TB150-7.5	3~	5.5	220 380	19 11.5	3.8/5.3	50/65	150mm	90/95	66
TB150-10	3~	7.5	220 380	26 15.5	3.8/5.3	60/75	150mm	90/95	75
TB150L-10	3~	7.5	220 380	26 15.5	5/6.5	40/53	150mm	90/100	80
TB200-15	3~	11	220 380	36 22	5/6.5	65/85	200mm	95/110	130
TB200-20	3~	15	220 380	47 28	5/7	90/100	200mm	95/110	140

性能表 Characteristic curves

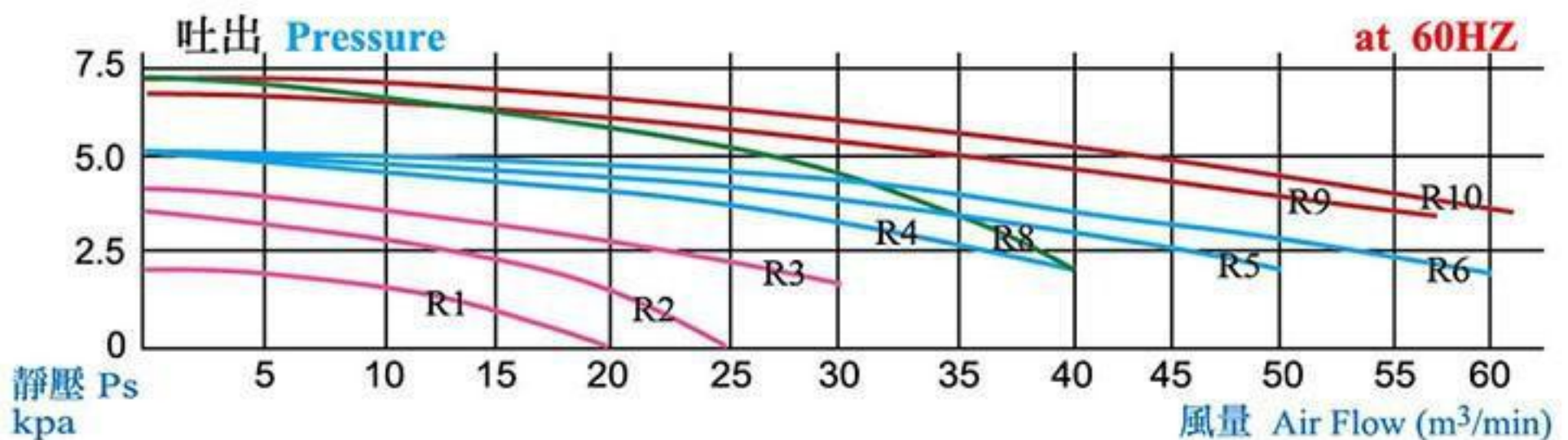
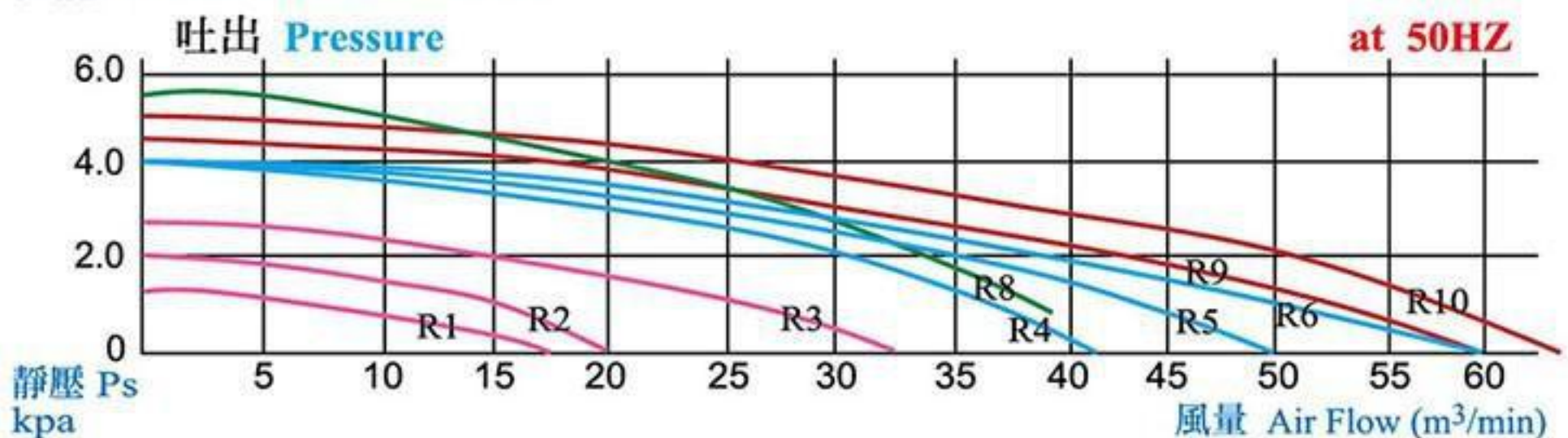

編號	品名	編號	品名	編號	品名	編號	品名
R1	TB100-1	R2	TB100-2	R3	TB125-3	R4	TB150-5
R5	TB150-7.5	R6	TB150-10	R8	TB150L-10	R9	TB200-15
R10	TB200-20						

透浦式鼓風機 Turbo Blower (Centrifugal Blower)

尺寸圖 Dimension (mm)

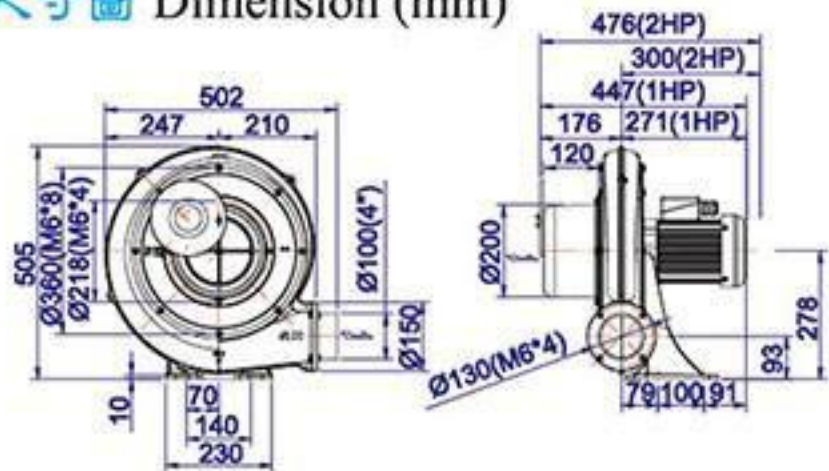

TB100-1 / TB100-2

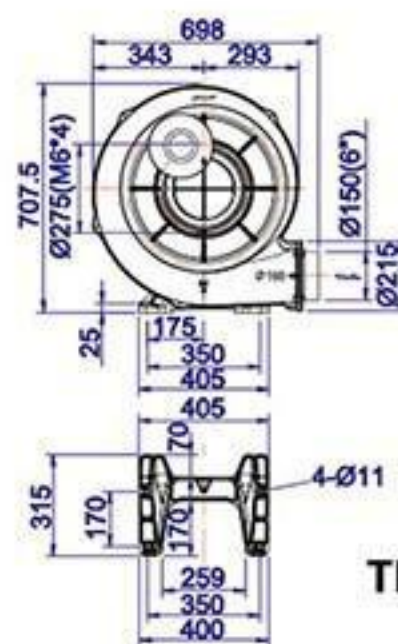
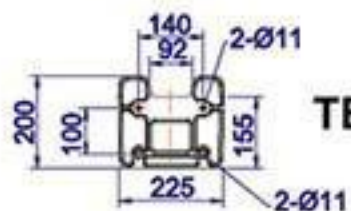

TB150-7.5 / TB150-10

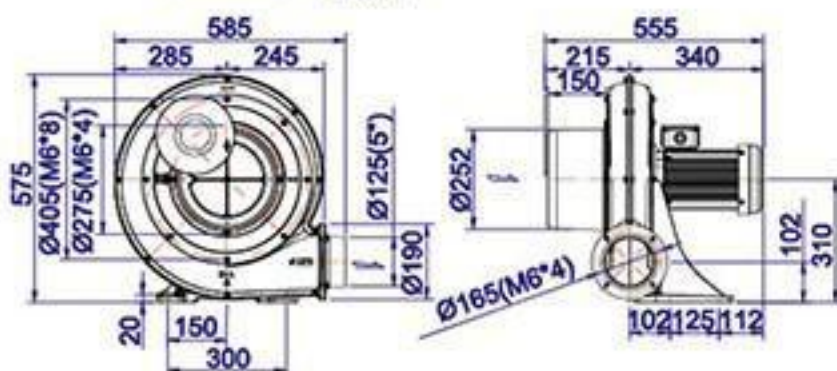
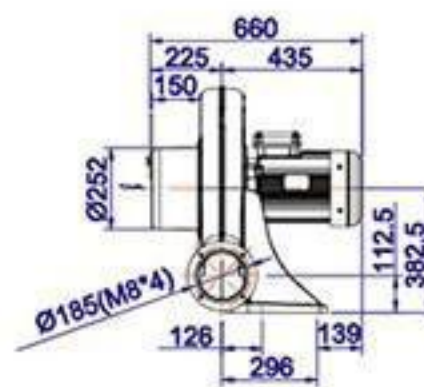

TB125-3

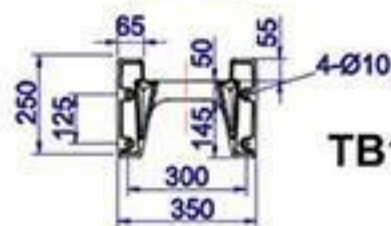

TB150L-10

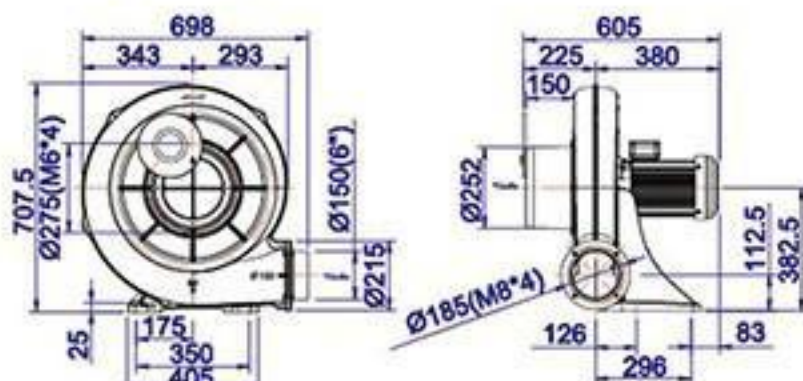
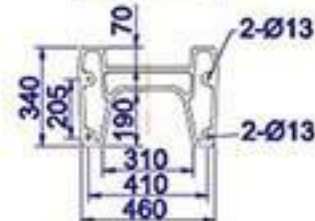

TB150-5

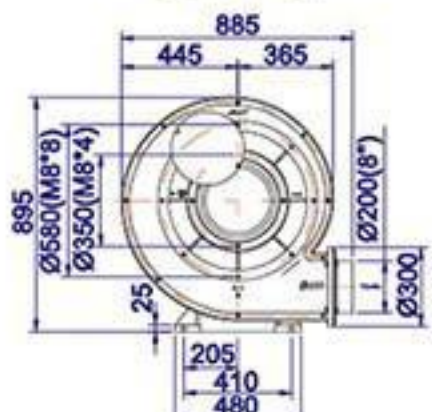
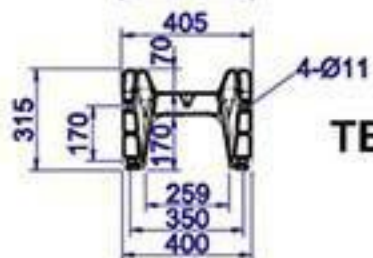

TB200-15 / TB200-20

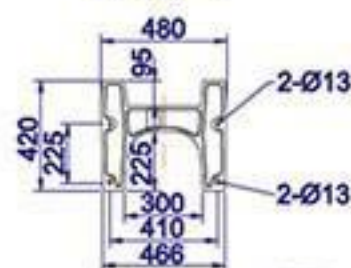

TB200-20



TB125-3

透浦多段式鼓風機 **Multi-Stage Turbo Blower (Centrifugal Blower)** at 50/60HZ

型式 Type	相數 Phase	功率 Output (KW)	電壓 Voltage (V)	電流 Current (A)	最大靜壓 (吐出) Pressure (Max.) (kpa)	最大風量 (吐出) Air Flow (Max.) (m ³ /min)	出口 口徑 Out Let (mm)	噪音 Noise Level (dB)	重量 Weight (Kg)
HTB75-032	3~	0.4	220 380	1.9 1.2	2.1/2.6	6/7	75mm	53/65	16
HTB75-053	3~	0.4	220 380	1.9 1.2	2.9/3.8	6.5/7.5	75mm	55/68	18
HTB75-104	3~	0.75	220 380	3 1.8	3.7/5	6.5/8	75mm	56/70	24
HTB75-105	3~	0.75	220 380	3 1.8	4.2/6	6.8/8.5	75mm	56/70	27
HTB100-102	3~	0.75	220 380	3 1.8	3.4/4.5	11/13	100mm	60/74	25
HTB100-203	3~	1.5	220 380	5.5 3.5	5/7	11/14	100mm	61/76	33
HTB100-304	3~	2.2	220 380	8 5	6.5/9	12.5/16	100mm	63/78	41
HTB100-505	3~	3.7	220 380	13 7.5	7.9/11	12.8/16.5	100mm	64/80	53
HTB125-503	3~	3.7	220 380	13 7.5	5.8/7.9	19/23	125mm	70/85	62
HTB125-704	3~	5.5	220 380	19 11.5	7.5/10.5	20/24	125mm	70/88	87
HTB125-1005	3~	7.5	220 380	26 15.5	9/13	20/24	125mm	72/90	109
HTB200-1502	3~	11	220 380	36 22	7/9	52/65	200mm	86/109	150
HTB200-2002	3~	15	220 380	47 28	8/10	56/70	200mm	88/110	170
2HTB65-503	3~	3.7	220 380	13 7.5	12/16	11/13	PF2 1/2"	70/85	73
2HTB65-704	3~	5.5	220 380	19 11.5	15/21	12/14	PF2 1/2"	70/85	104
2HTB65-1005	3~	7.5	220 380	26 15.5	18/26	13/15	PF2 1/2"	70/85	118

性能表 **Characteristic curves**

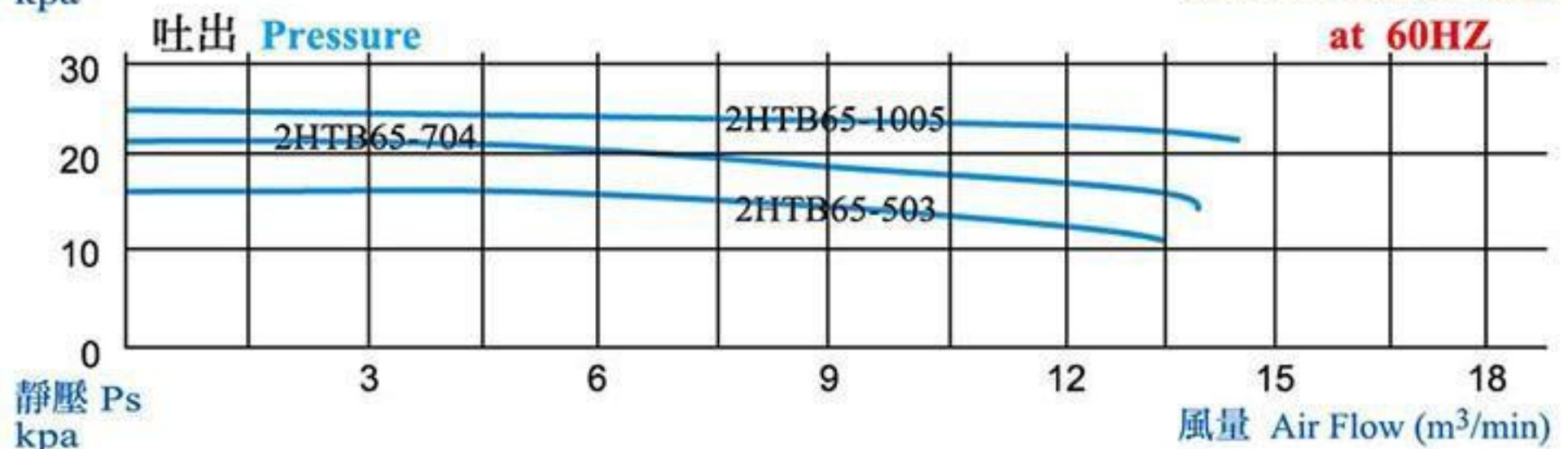
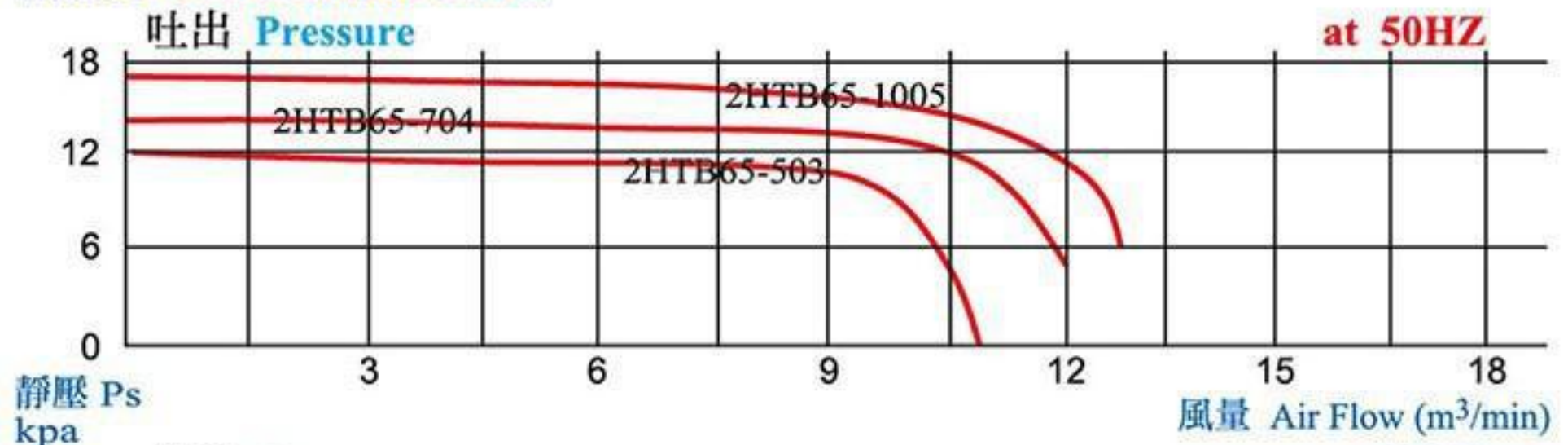

透浦多段式鼓風機 Multi-Stage Turbo Blower (Centrifugal Blower)

性能表 Characteristic curves

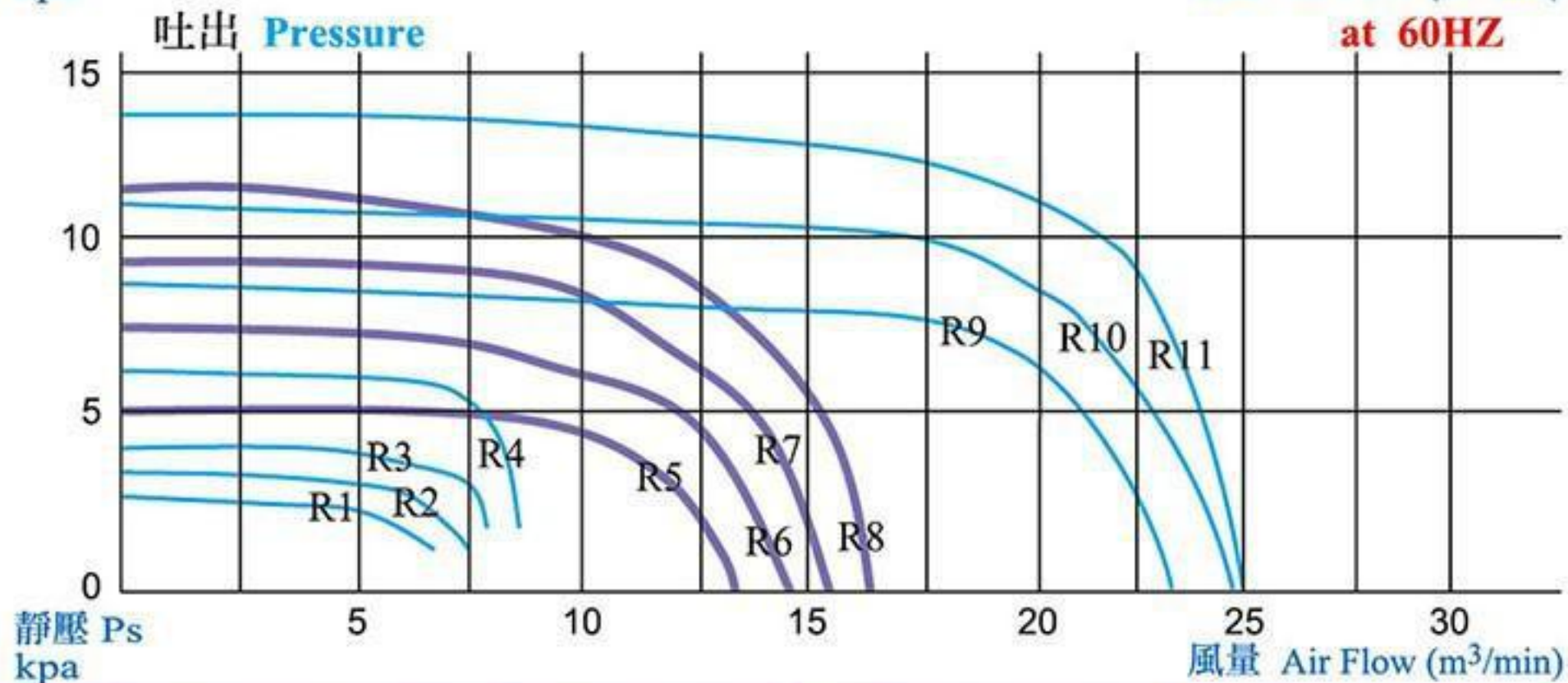
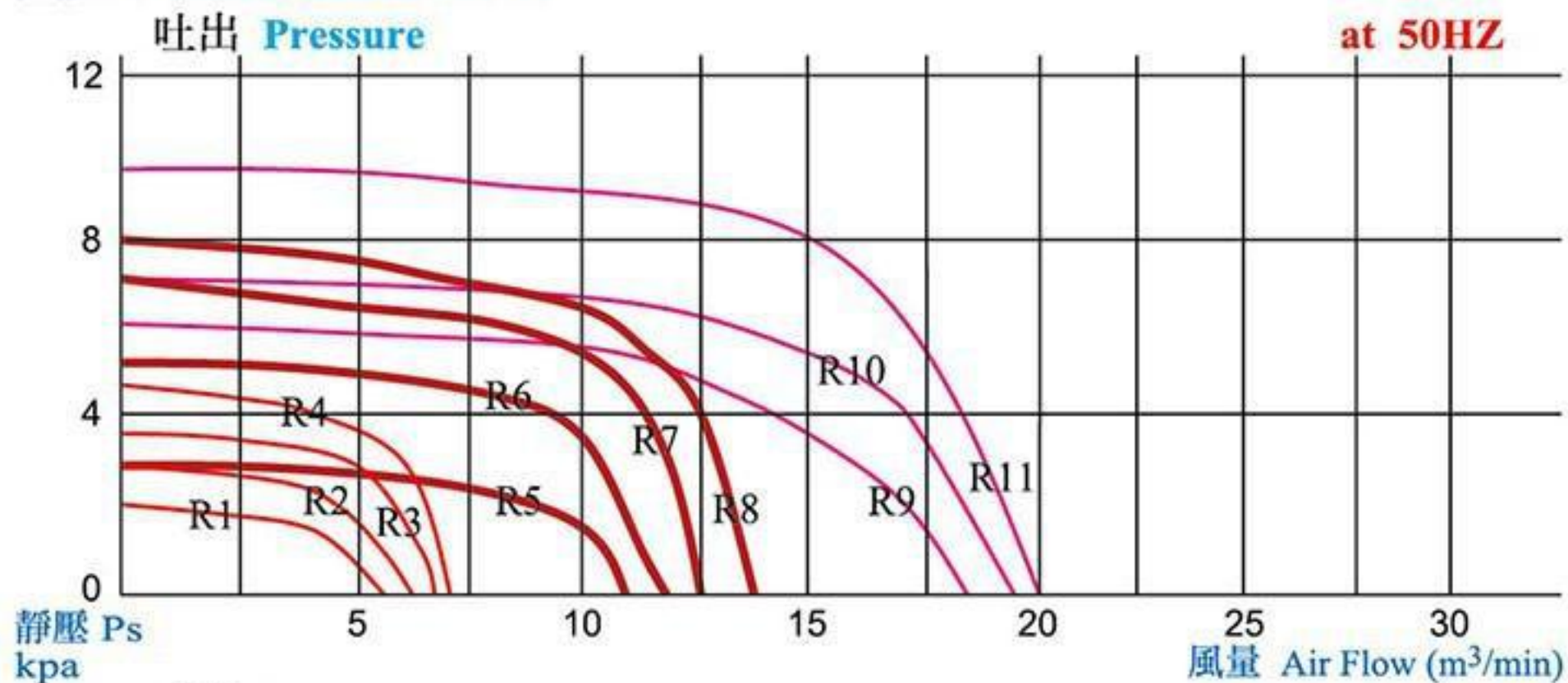

編號	品名	編號	品名	編號	品名	編號	品名
R1	HTB75-032	R2	HTB75-053	R3	HTB75-104	R4	HTB75-105
R5	HTB100-102	R6	HTB100-203	R7	HTB100-304	R8	HTB100-505
R9	HTB125-503	R10	HTB125-704	R11	HTB125-1005		

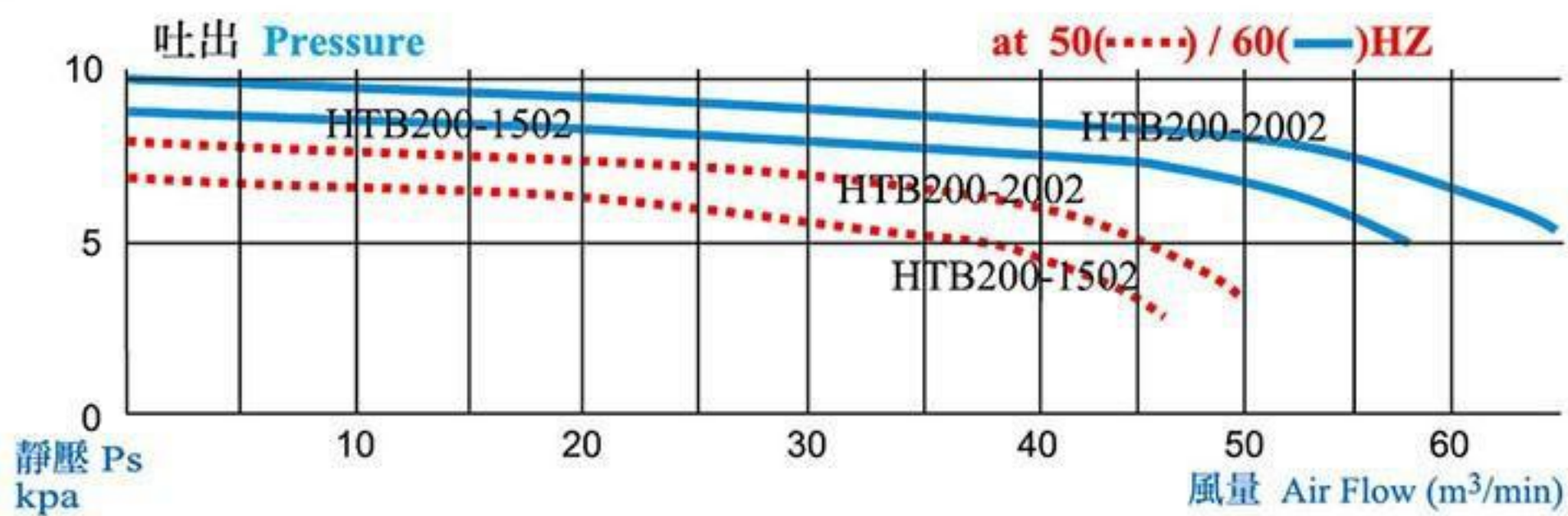

透浦多段式鼓風機 Multi-Stage Turbo Blower

尺寸圖 Dimension (mm)

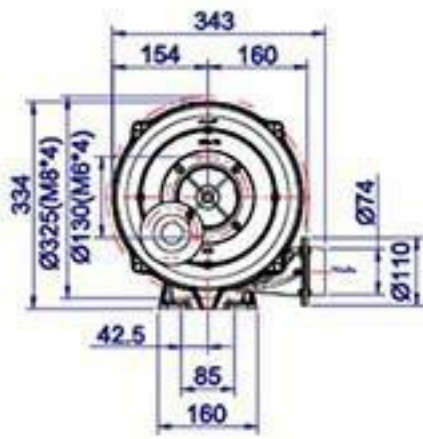

HTB75-032 2-stage

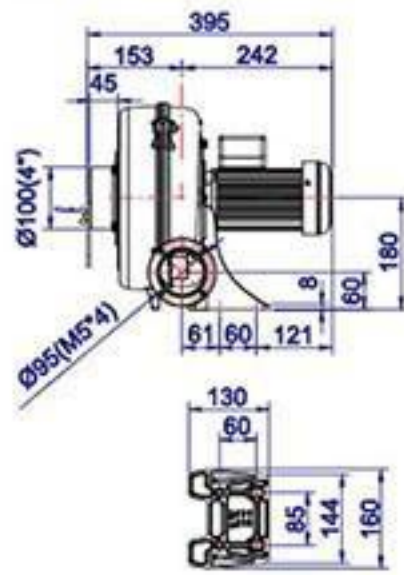

HTB100-102 2-stage

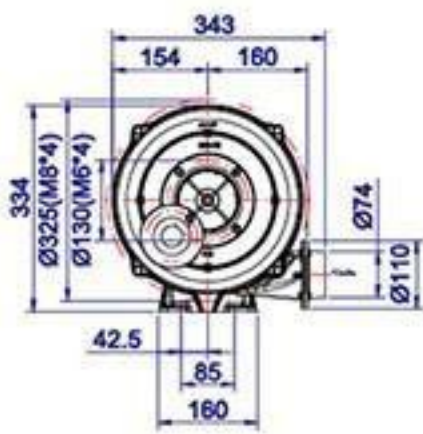

HTB75-053 3-stage

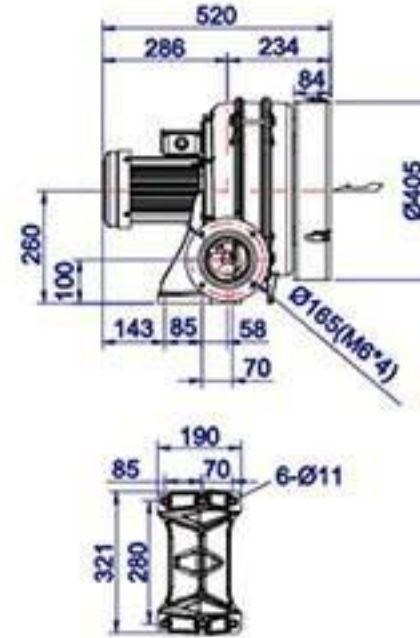
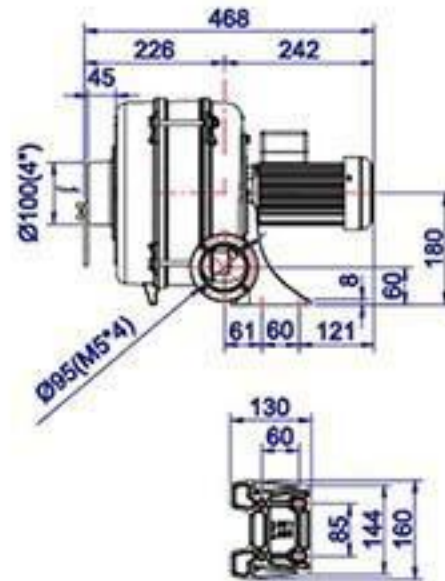

HTB100-203 3-stage

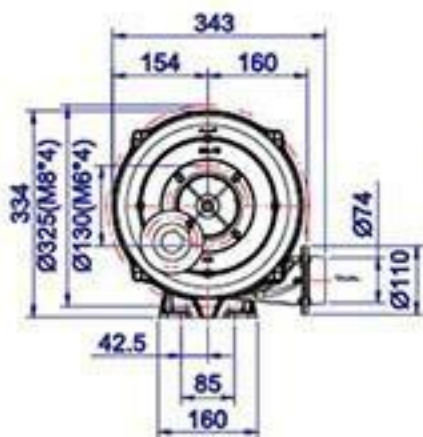

HTB75-104 4-stage

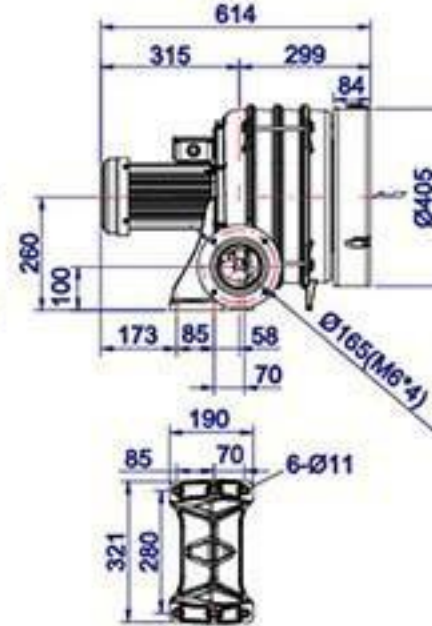
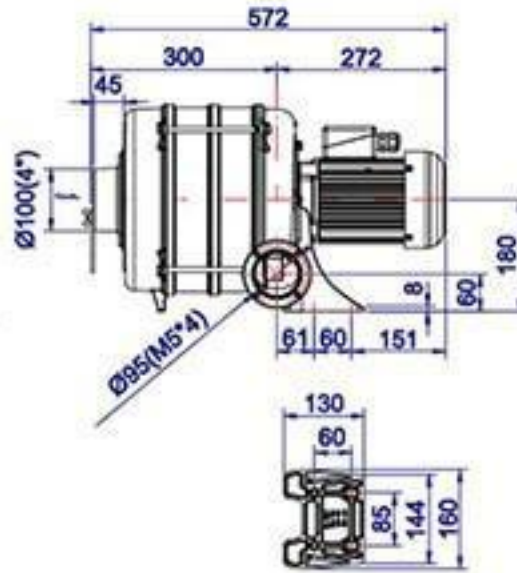

HTB100-304 4-stage

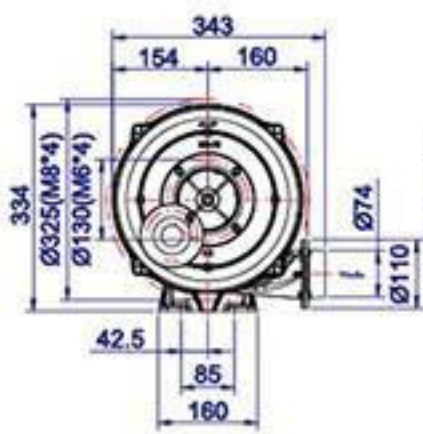

HTB75-105 5-stage

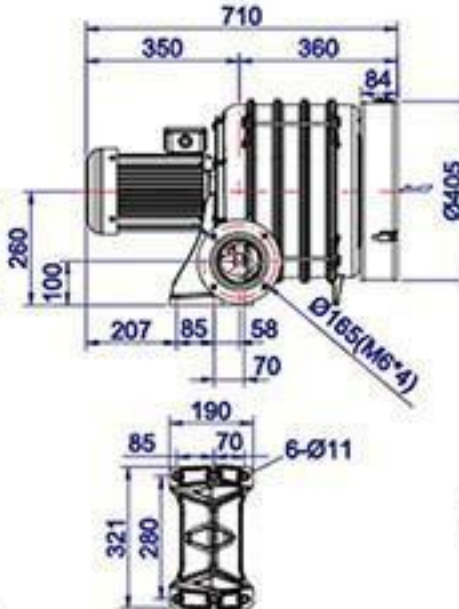
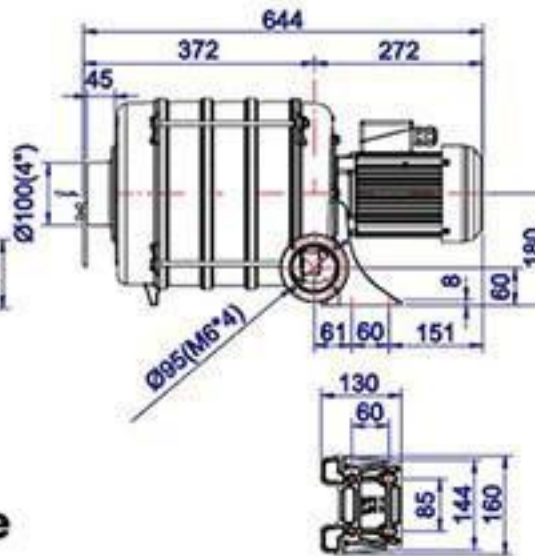

HTB100-505 5-stage



透浦多段式鼓風機 Multi-Stage Turbo Blower

尺寸圖 Dimension (mm)

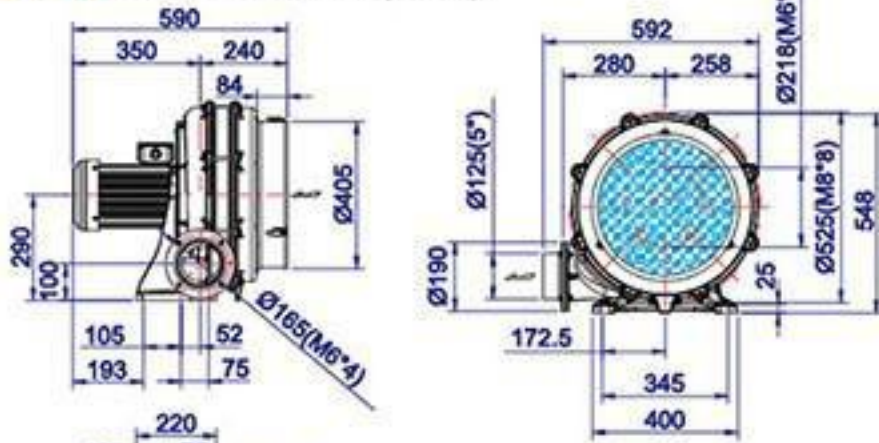

HTB125-503 5HP 3-stage

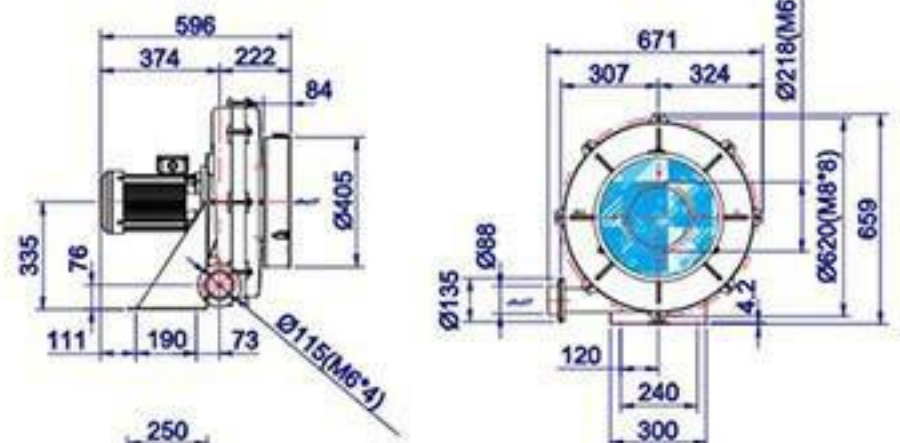

2HTB65-503 5HP 3-stage

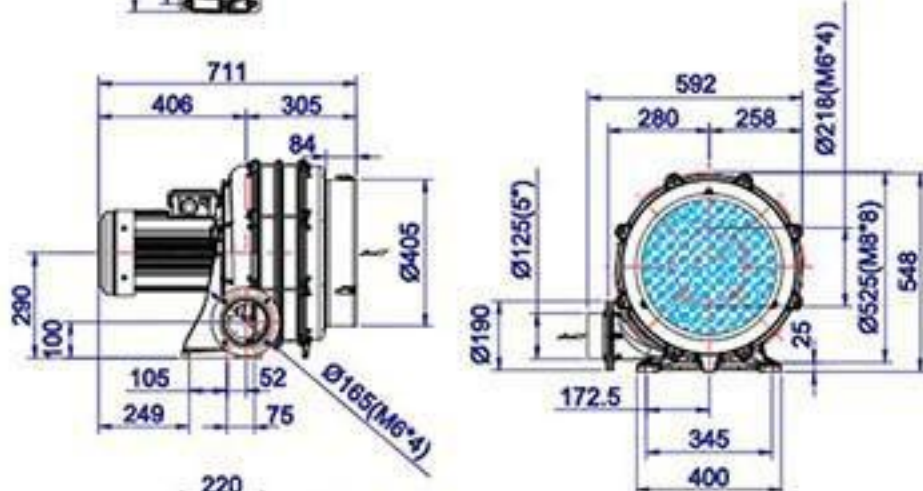

HTB125-704 7.5HP 4-stage

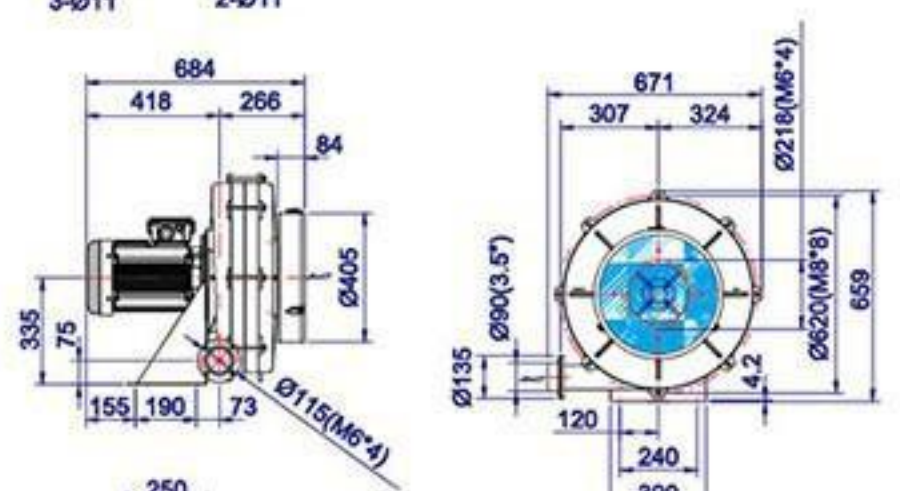

2HTB65-704 7.5HP 4-stage

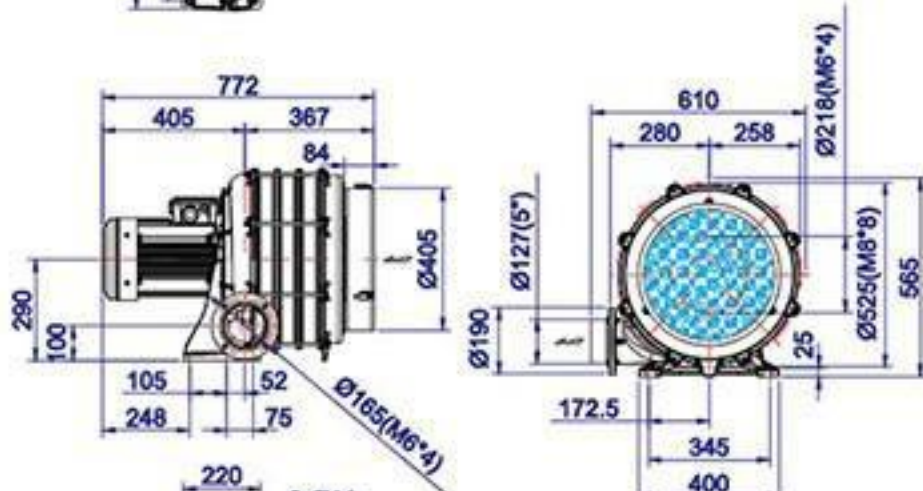

HTB125-1005 10HP 5-stage

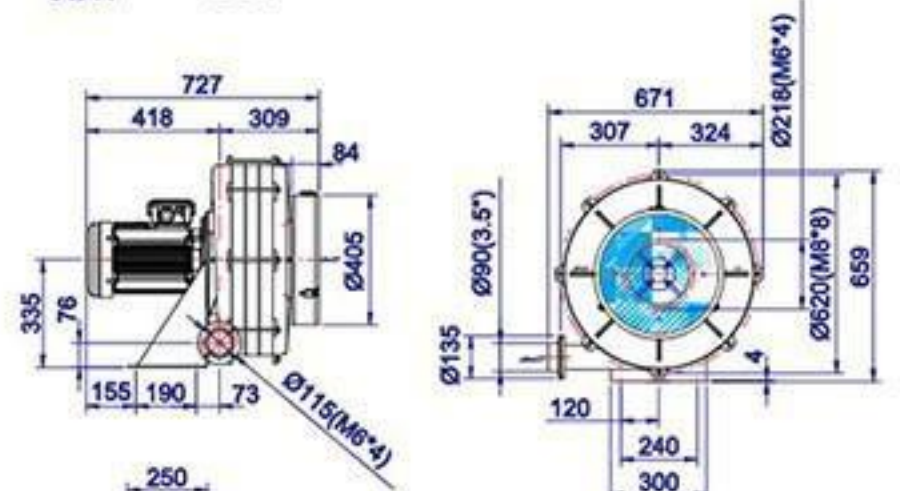

2HTB65-1005 10HP 5-stage

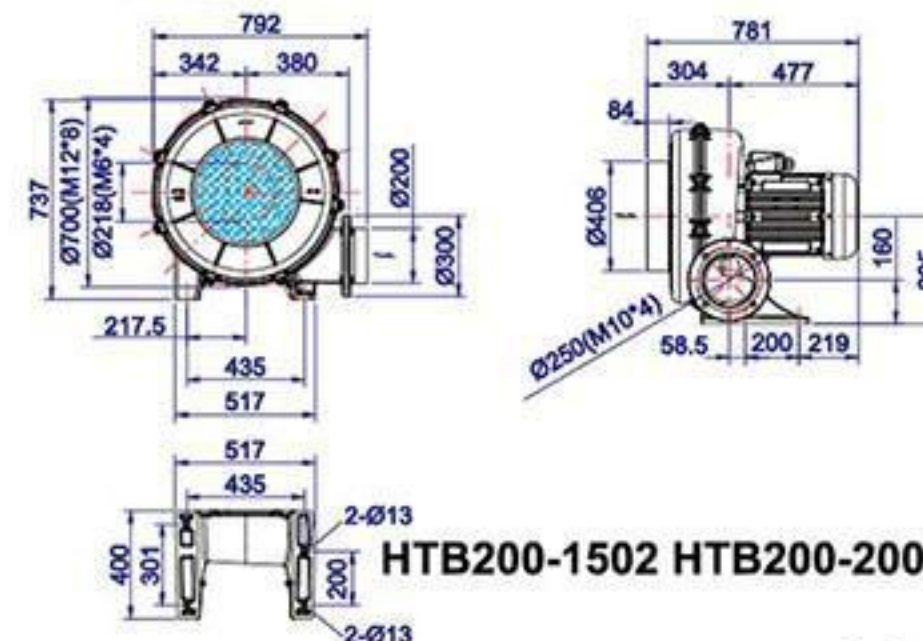

HTB200-1502 HTB200-2002



HTB125-1005

HTB125-704

隔熱型鼓風機 Heat-Resistant Turbo Blower

at 50/60HZ

型式 Type	相數 Phase	功率 Output (KW)	電壓 Voltage (V)	電流 Current (A)	最大靜壓 (吐出) Pressure (Max.) (kpa)	最大風量 (吐出) Air Flow (Max.) (m ³ /min)	吸入/吐出 口徑 In/Out Let (mm)	噪音 Noise Level (dB)	重量 Weight (Kg)	最大吸氣 溫度 Suction Temperature (max)
CX-75SAH	1~ 3~	0.4	1Ø 220 220/380	2.5 1.9/1.2	1.1/1.6	7/8	IN 100mm OUT 75mm	56/70	10	180°C
CX-75AH	1~ 3~	0.74	1Ø 220 220/380	5 3/1.9	1.7/2.4	13/15	IN 125mm OUT 100mm	64/80	17	
CX-100AH	3~	1.5	220/380	5.5/3.5	2/3	20/23	IN 125mm OUT 100mm	74/90	28	
CX-125AH	3~	2.2	220/380	8/5	2.4/3.7	25/32	IN 125mm OUT 125mm	76/95	38	
CX-150AH	3~	3.7	220/380	13/7.5	3.2/4.4	35/45	IN 150mm OUT 150mm	80/100	59	

尺寸圖 Dimension (mm)

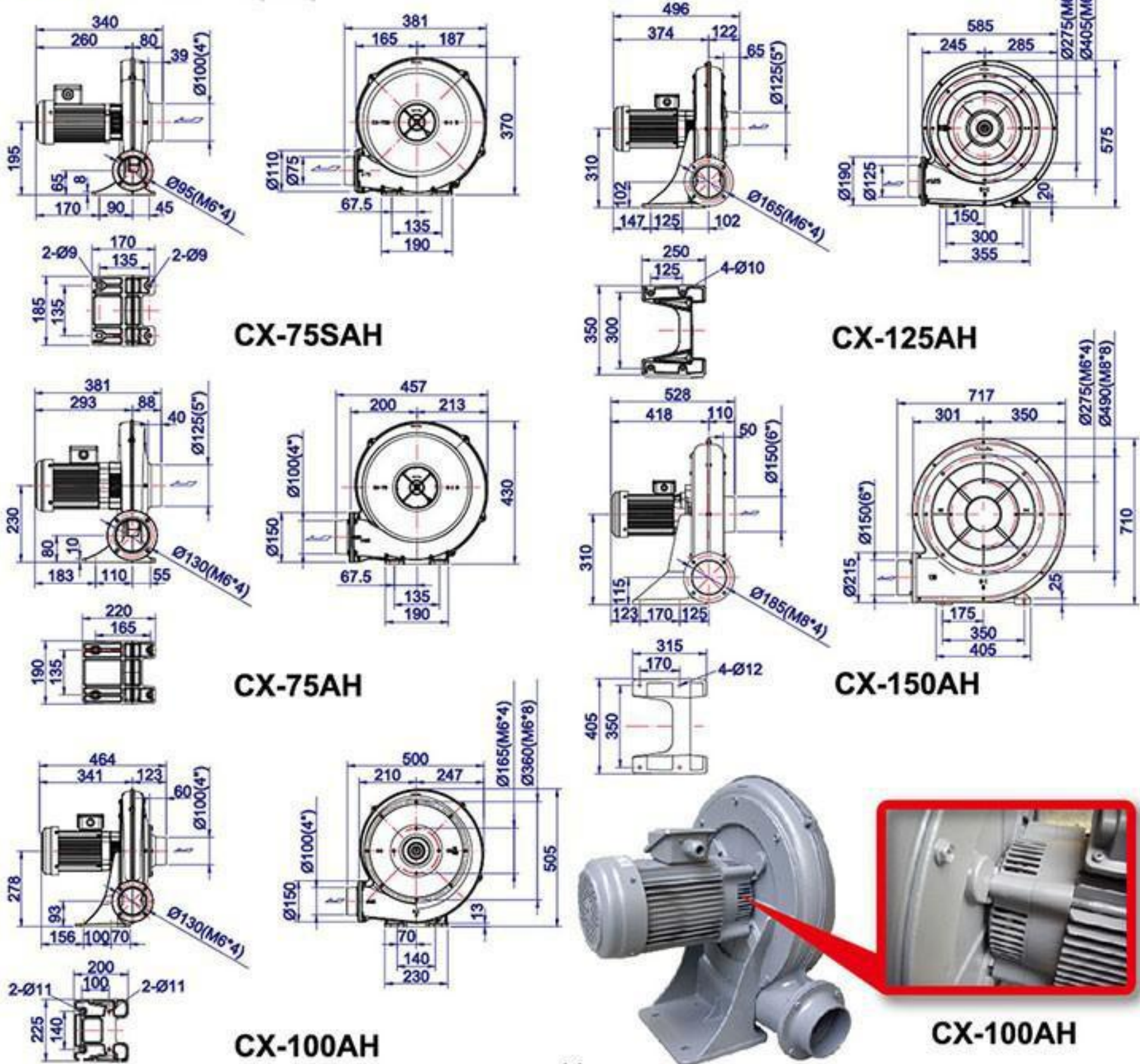

噴射氣送管 Air Jet Transportation Pipe

尺寸圖 Dimension (mm)

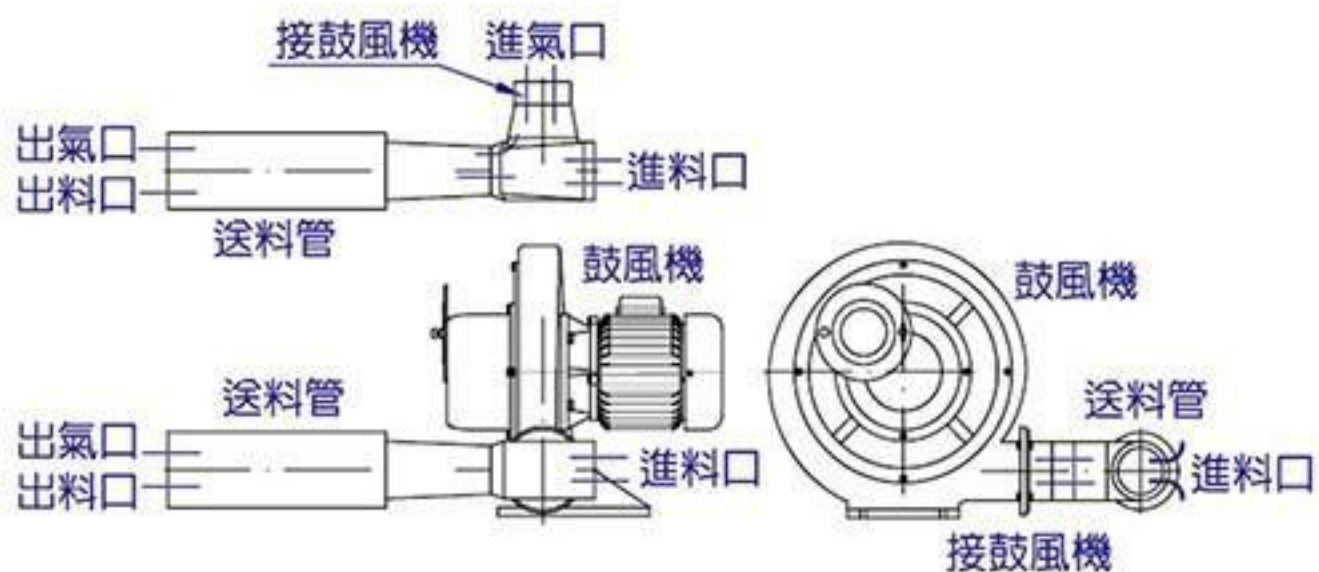

JET 4" JET 6" JET 8"

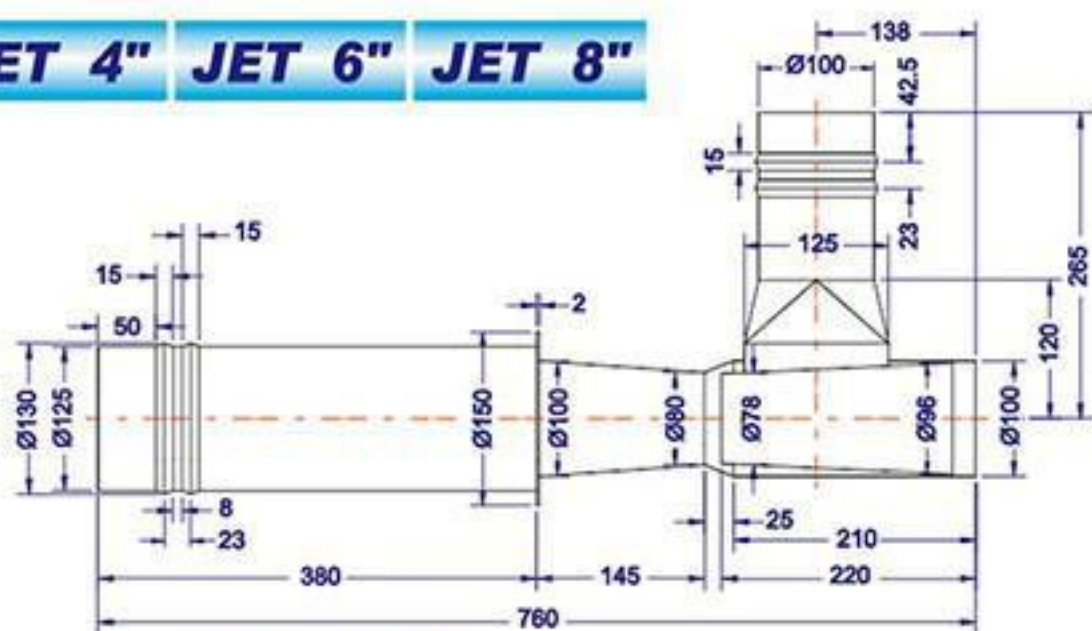

JET 4"

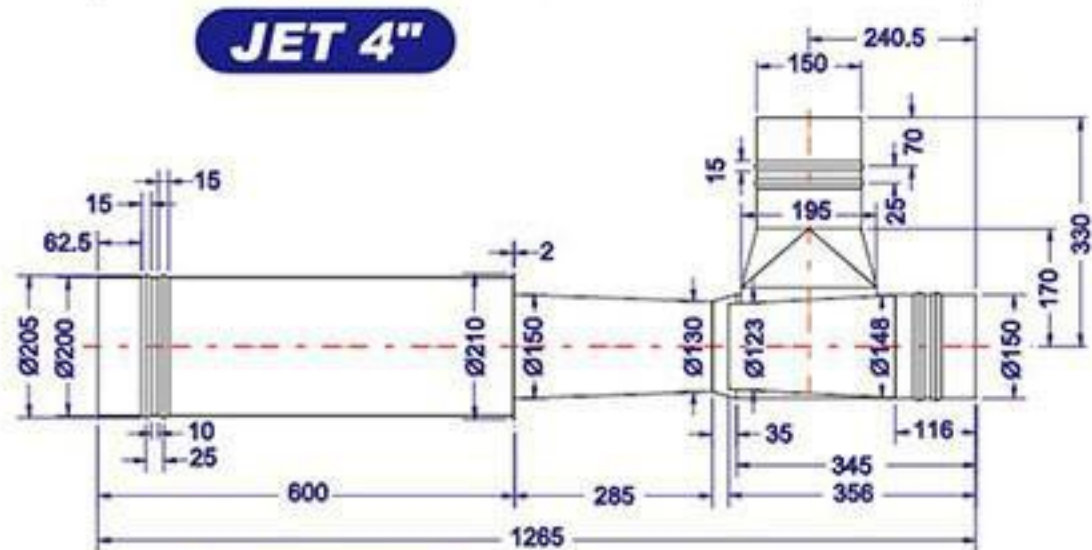

JET 6"

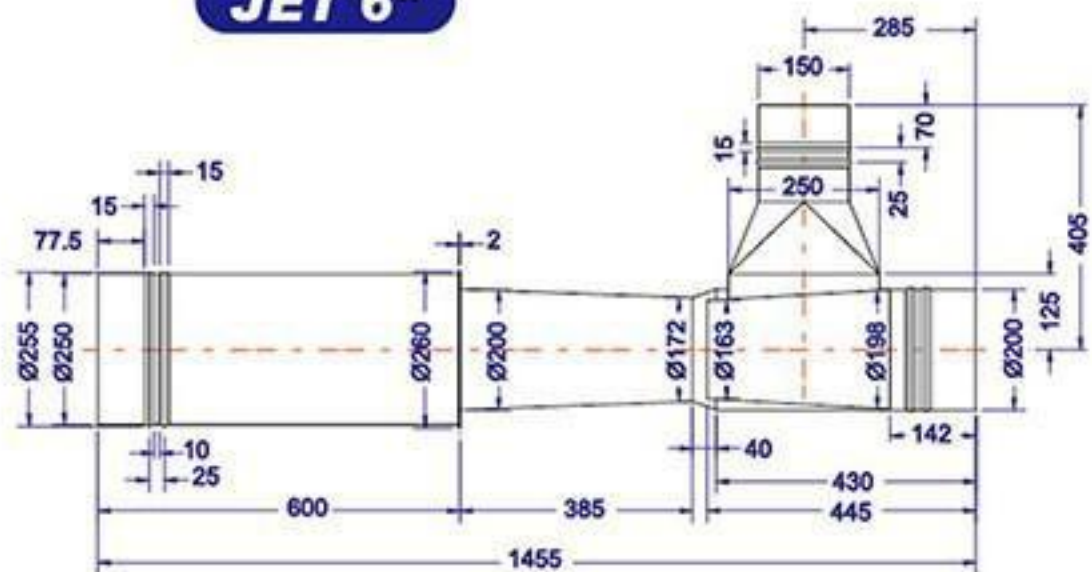

JET 8"



鋁合金高效率均壓風刀

ALUMINUM AIR KNIFE

產品特點：本風刀是由全風公司所研發，以鋁合金擠壓一體成型，雨滴型整流結構，風壓風量均勻，壓損低，構造單純，材質堅固，組裝容易。可調式出風口設計，出風口的氣流是單方向吹出設計，滿足多元化生產需要。

應用：吹除工件表面的水份或油份、冷卻降溫、熱風吹乾等....。



型號	AK50-300-1	AK50-400-1	AK50-600-1	AK50-900-1 AK50-900-2	AK50-1200-1 AK50-1200-2
入風口徑 /數量	50mm X 1	50mm X 1	50mm X 1	50mm X 1 50mm X 2	50mm X 1 50mm X 2
長度	300mm	400mm	600mm	900mm	1200mm
出風口 寬度	0.5~2mm	0.5~2mm	0.5~2mm	0.5~2mm	0.5~2mm

型號	AK75-500-1	AK75-1000-1	AK75-1200-1 AK75-1200-2	AK75-1500-1 AK75-1500-2	AK75-1800-1 AK75-1800-2
入風口徑 /數量	75mm X 1	75mm X 1	75mm X 1	75mm X 1 75mm X 2	75mm X 1 75mm X 2
長度	500mm	1000mm	1200mm	1500mm	1800mm
出風口 寬度	1~3mm	1~3mm	1~3mm	1~3mm	1~3mm

適用鼓風機概算

所需風量(m³/min)=風刀長度(m)X出風口寬度(m)X希望風速(m/sec)X60X(1.2~1.5)
所需靜壓(kPa)

風刀出口寬度	1mm	2mm	3mm	4mm
所需靜壓	10kPa 以上	5~15kPa	3~8kPa	2~5kPa

P.S. 上述資料須在(使用點)上計算

AK50

單向入口

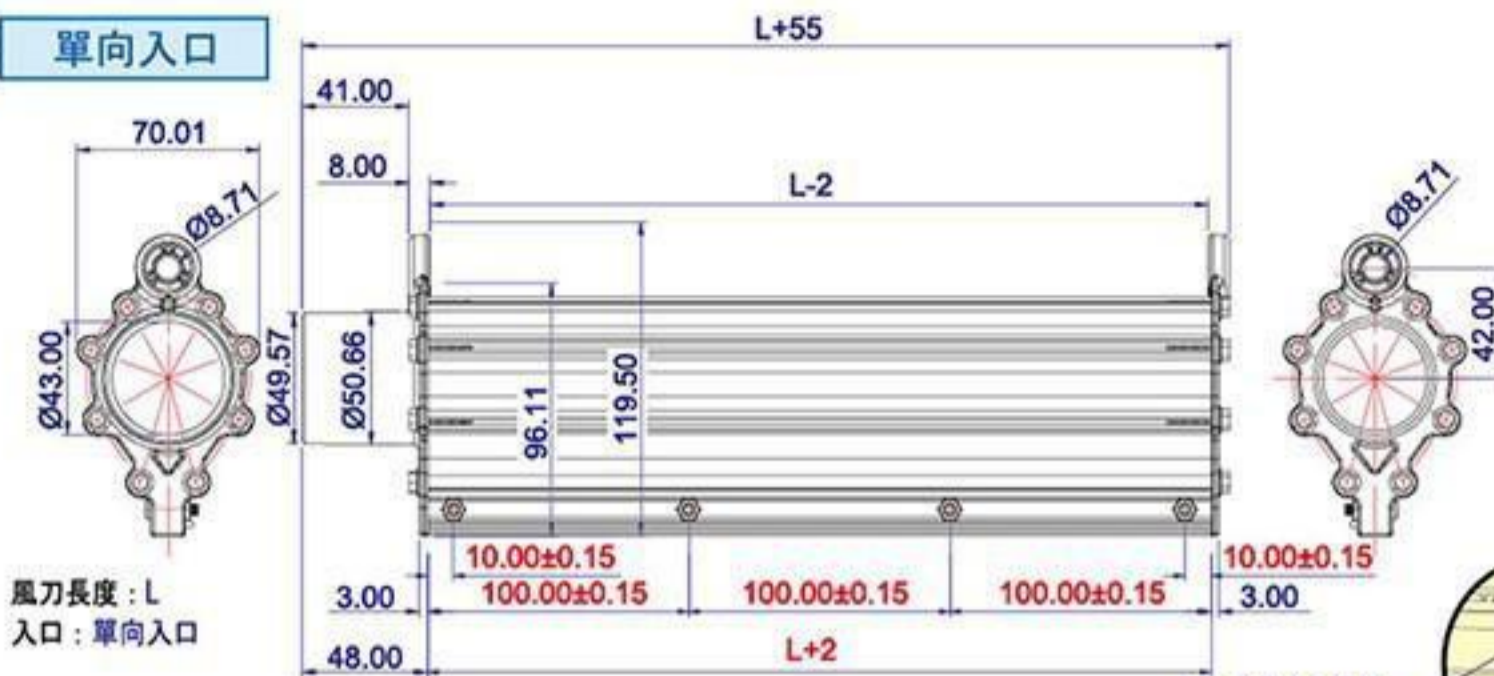

雙向入口

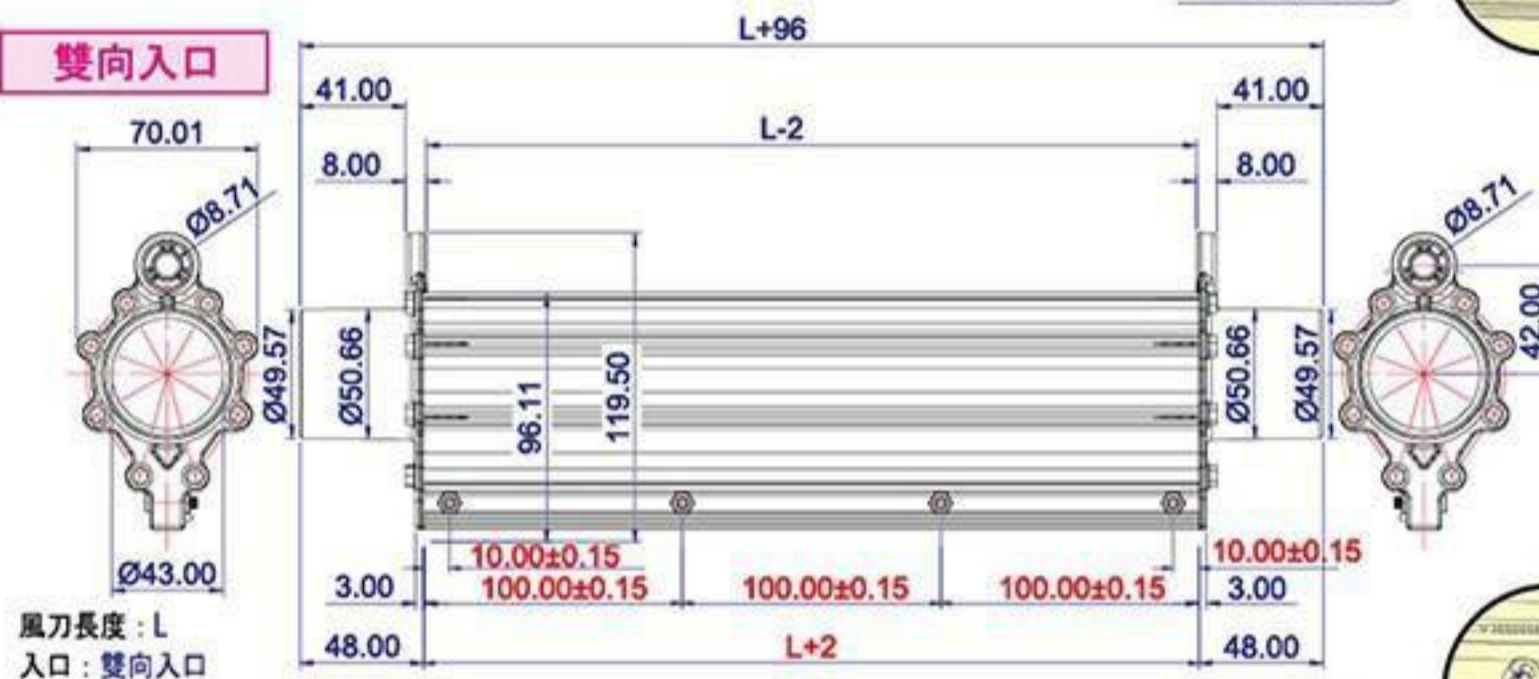

AK75

單向入口

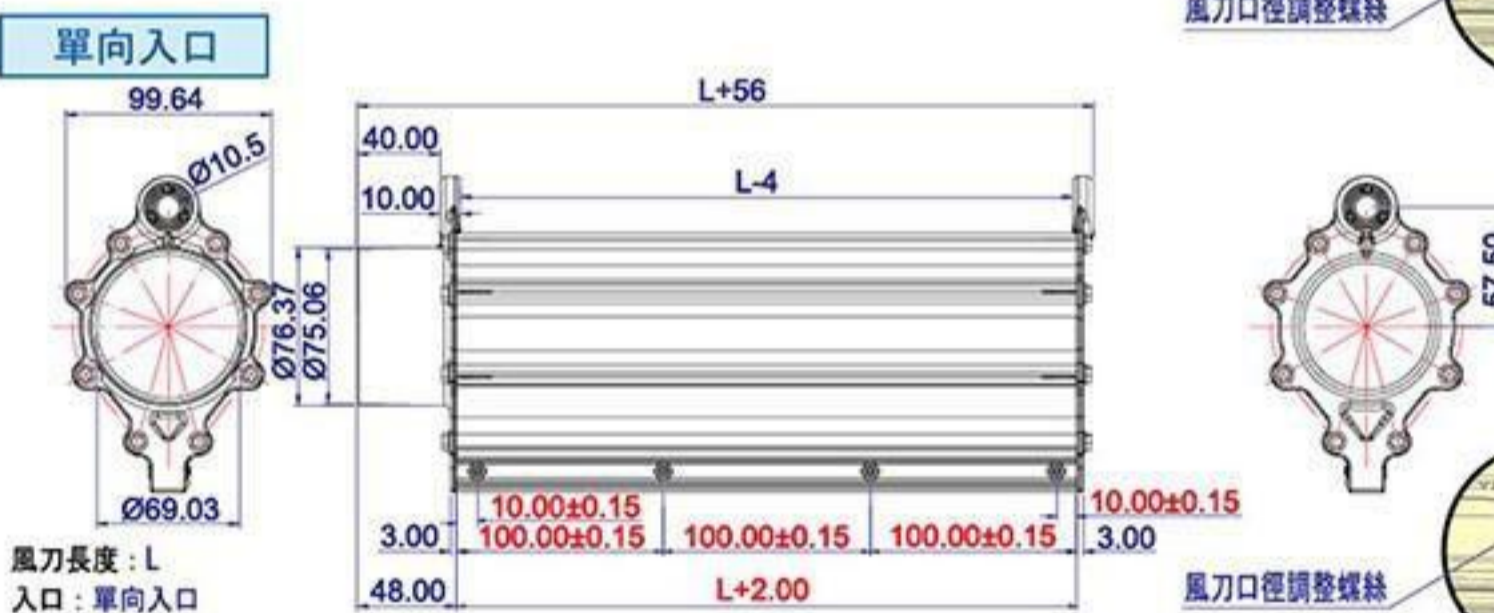

雙向入口

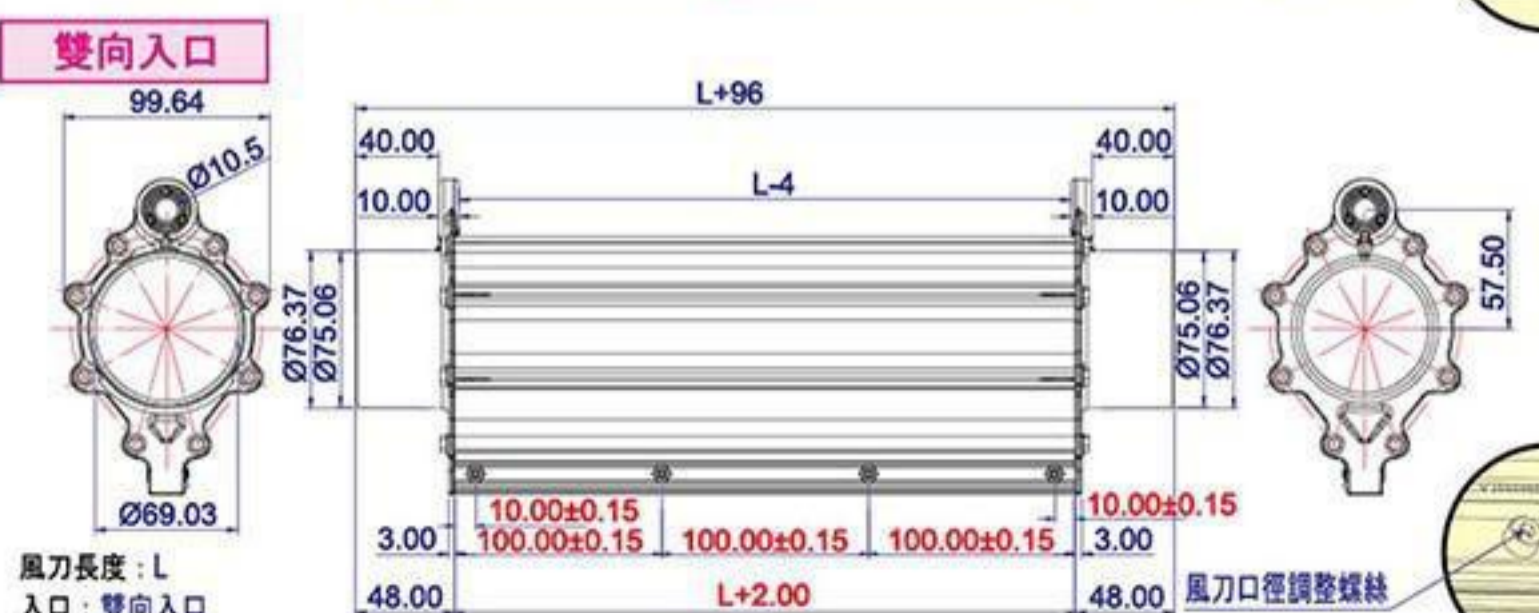



批發 · 製造 · 買賣 Manufacturer · Distributor



全風機電設備(昆山)有限公司

Chuanfan Mechanical and Electrical Equipment (Kunshan) Co., Ltd

地址: 江蘇省昆山市玉城南路268號
Add: No.268 Yucheng South Road, KunShan City,
JiangSu Province.

電話/Tel: 0512-57730082/3 57730087/9

傳真/Fax: 0512-57730081

郵編/PostCode: 215316

E-mail: sales@quan-fan.com.cn

http: //www.chuanfan.com.cn