

IMPROVING AND EVOLVING
KUNSHAN HI-MACH TECH CO.,LTD

HI-MACH®

KUNSHAN HI-MACH TECH CO.,LTD

HI-MACH®

昆山利玛赫自动化科技有限公司
KUNSHAN HI-MACH TECH CO.,LTD



+86-512-57920071
jack@hemach.com
中国·昆山

TELEPHONE NUMBER · E-MAIL · ADDRESS



WWW.HEMACH.COM

2024



COMPANY INTRODUCTION

利玛赫自动化科技有限公司，是以焊接技术为核心，自动化控制技术为载体的智能装备研发生产型企业。

公司具备完善的设备研发团队，软件开发团队和工艺技术团队，自公司成立至今已在新能源汽车，半导体和仪器仪表行业获得多项发明和相关专利。公司专注于产品工艺和技术拓展，以智能控制技术相结合，致力于研发生产各类型自动化智能装备。公司研发生产的智能化装备应用于：新能源汽车，机械制造，军工和电子消费品等行业的组装，运载，检测，焊接和金属熔覆等。

目录

Table of Contents

发展历程	P01
企业文化	P02
产品发展	P03
产品概述	P05

自动化设备

波纹管自动焊接解决方案	P07
软管类自动焊接解决方案	P13
焊接波纹管专机系列	P17
仪表类自动焊接解决方案	P23
定制类自动焊接解决方案	P29
管/法兰自动焊接解决方案	P33
管类自动焊接定制	P39
直缝类自动焊接定制	P41
堆焊自动化	P43

智能生产线

机器人系统集成	P45
自动化生产线	P47
技术团队	P49
专利资质	P51



发展历程

DEVELOPMENT HISTORY

企业文化

CORPORATE CULTURE

2012年	2012年8月由LD控制技术和HI-MACH合并成了利玛赫品牌
2013年	2013年研发多款自动焊接机
2015年	2015年成为民营科技企业
2019年	2019年荣获高新技术企业
2020年	2020年推出全新概念的焊接类技术控制系统
2022年	公司通过TUV ISO9001质量管理体系认证

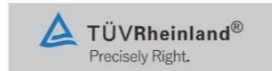

以竞争求生存，以稳定求市场，以创造求发展
Competition for coexistence, stability for the market, to create for development



以专业出规范，以细致出精品，以专业铸品质，永远追求以更好的质量赢得客户的超值满意
To professional standards, to meticulous quality, to professional casting quality will always pursue a better quality to win customer satisfaction value



追求卓越，创造完美，诚信敬业，建立标准
The Pursuit of excellence, create perfect, integrity and professionalism, the establishment of standards



PROCESS

产品发展历程

焊接和自动化已超越了两者的拼凑，将焊接工艺和自动逻辑互联互通，并加载了UR技术和力矩控制逻辑，让用户得到更好的体验效果，简化专业技能人员培训周期，提高生产效率。

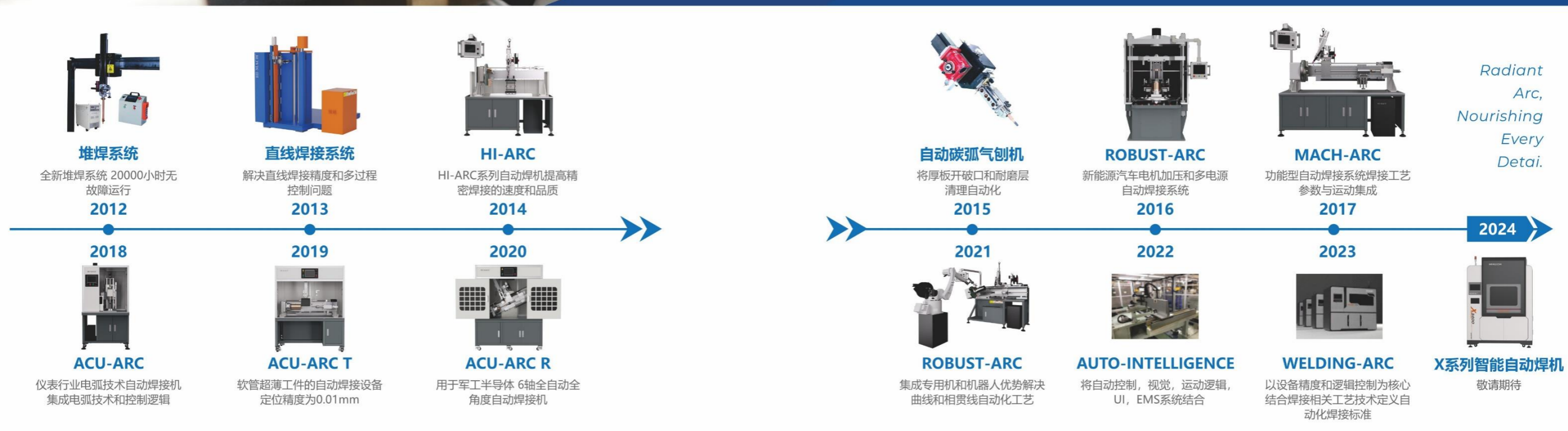

利玛赫基于不同行业对焊接工艺技术的需求，设计和规范了自身的机械架构体系 — HI-MACH STRUCTURE标准组件。我们融入了VI人体工学设计，结合行业规范要求，对复杂的机械结构进行优化、整合和技术延伸，从L型、H型到C型、R型和X型。结合自身控制技术和电弧控制优势，我们将不同类型的电源与机械结构完美结合，简化了复杂的电流控制、送丝、摆动和AVC电弧系统，极大地降低了各种焊接工艺的学习门槛。

Based on the welding process technology requirements of different industries, LIMAH has designed and standardized its own mechanical structure system - the HI-MACH STRUCTURE standard components. We have incorporated VI ergonomics design, combined with industry-specific requirements to optimize, integrate, and extend complex mechanical structures from L-shaped, H-shaped to C-shaped, R-shaped, and X-shaped. Leveraging our control technology and arc control advantages, we seamlessly integrate different types of power sources with mechanical structures, greatly simplifying various welding processes by combining complex current control, wire feeding, oscillation, and AVC arc systems.

璀璨之弧，细致入微。

Radiant Arc, Nourishing Every Detail.

我们拥有专业的焊接工艺工程师（IWE）和焊接技师（IWS）团队，能够对不同行业的电弧技术进行完美的诠释。通过我们技术团队的支持，客户可以获得高质量、高效率的焊接解决方案，满足其特定行业的需求。

Our team of professional welding process engineers (IWE) and welding technicians (IWS) can perfectly interpret different arc technologies in various industries. With our technology and team support, customers can obtain high-quality, efficient welding solutions tailored to their specific industry needs.

01

HI-ARC系列：专注于解决单一产品种类的批量化自动焊接需求。

HI-ARC Series: Focuses on meeting the batch automatic welding needs of a single product type.

02

MACH-ARC系列：适用于多个焊接接缝的重复自动焊接任务。

MACH-ARC Series: Designed for repetitive automatic welding tasks with multiple weld seams.

03

ROBUST-ARC系列：采用力矩控制逻辑与焊接工艺结合，降低因焊接导致的产品形变。

ROBUST-ARC Series: Combines torque control logic with welding processes to reduce product deformation caused by welding.

04

ACU-ARC系列：全角度多功能自动焊接机，基于AVC和HI-MACH PID算法，实现产品的自动焊接轨迹控制，包括圆弧和直线逻辑轨迹。

ACU-ARC Series: Fully-angle multifunctional automatic welding machine, based on AVC and HI-MACH PID algorithms, to achieve automatic welding trajectory control for products, including circular and linear logical trajectories.

05

MIRCO-ARC系列：专为0.03mm至1mm超薄材料的自动焊接而设计。

MIRCO-ARC Series: Specifically designed for automatic welding of ultra-thin materials ranging from 0.03mm to 1mm.

06

SUPER PULSE系列：适用于特殊材料如铜、镍、锆等的焊接应用。

SUPER PULSE Series: Suitable for welding applications of special materials such as copper, nickel, and zirconium.

HI-MACH®

高质高效的焊接解决方案

High-quality, high-efficiency welding solutions

METAL BELLOWS CUTTING AND WELDING MACHINE

波纹管切割与焊接

我们专注于解决各类型法兰与波纹管的自动焊接，提供单机和整体解决方案。

Automatic welding for metal bellows and flanges, sales of standalone machines and bellows production lines.



波纹管激光下料机

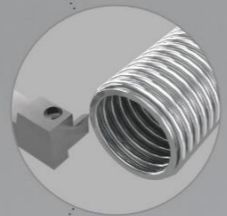

波纹管焊口切平机

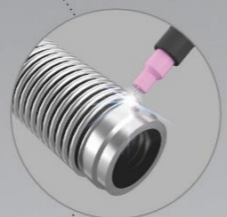

波纹管管口焊接机



ROBUST-ARC

波纹管焊接解决方案



丰富行业技术基础以及与行业用户紧密合作，我们能为客户提供全方位的波纹管解决方案。从料带成型到波纹管成型，再到整管下料和焊口处理，我们致力于为客户提供完整生产设备和技术服务。

Provide a variety of standalone machines for the metal bellows industry, such as tube making machines, forming machines, cutting machines, notching machines, welding machines, and complete production lines for metal bellows.



Laser Tube Cutting

■ CUT 06/60 激光下料机

- 激光下料机利用高能激光束，实现对波纹管的自动切割，切割速度快、精度高、切割面光滑。适用于直径6mm-450mm，壁厚0.05-3mm的不锈钢、碳钢、铝合金等多种材料的切割下料。
- The laser tube cutting machine uses a high-energy laser beam to achieve automatic cutting of metal bellows, with fast cutting speed, high precision, and a smooth cutting surface. It is suitable for cutting and processing materials such as stainless steel, carbon steel, and aluminum alloy with diameters ranging from 6mm to 450mm and wall thicknesses from 0.05mm to 3mm.



产品型号 Product name	切割直径(mm) diameter range	切割厚度(mm) Cutting capacity	入力电压(V)-功率(KW) primary Volt-age(50-60Hz)	外形尺寸(mm) Dimensions H×W×D
CUT 06	6-60	0.05-1	380/3	850*750*1650
CUT 35	25-180	0.1-2	380/5.5	850*1100*1800
CUT 60	180-450	0.1-3	380/7.8	1000*1200*1800

Tube End Turning Machine



HI-MACH

■ HI-CUT 06/35 波纹管焊口切平机

- 采用机械车切的方式，将波纹管的焊口精确切割至与法兰/接管相同尺寸，有效降低试焊过程中因波纹管焊口尺寸不一致而造成的焊接质量问题。适用于直径6mm-450mm，壁厚0.05mm-2mm的不锈钢、碳钢、铝合金等多种材料的波纹管焊口加工。
- By utilizing the mechanical car cutting method, the welding joint of the bellows is precisely cut to the same size as the flange/tube, effectively reducing welding quality issues caused by inconsistent sizes of the bellows welding joints during the welding process. This method is suitable for processing the welding joints of bellows with diameters ranging from 6mm to 450mm and wall thicknesses from 0.05mm to 2mm, made of various materials such as stainless steel, carbon steel, aluminum alloys, and more.



产品型号 Product name	切割直径(mm) diameter range	切割厚度(mm) Cutting capacity	入力电压(V)-功率(KW) primary Volt-age(50-60Hz)	外形尺寸(mm) Dimensions H×W×D
HI-CUT 06	6-60	0.05-0.5	380/3.2	1150*900*1300
HI-CUT 18	25-180	0.1-1	380/7.8	950*1230*1500
HI-CUT 40	180-450	0.1-2	380/8.5	1080*1200*2015



ROBUST-ARC 06/35

波纹管管口焊接机

本机结合力矩技术和双驱动同步控制，以微电弧特性为基础，有效解决了薄壁波纹管与法兰的焊接工艺技术。这种技术组合能够精准控制焊接过程中可能产生的变形和中心偏差，从而提升焊接质量并提高生产效率。

适用于直径6mm-450mm，壁厚0.03mm-2mm的不锈钢、碳钢、铝合金等多种材料的波纹管和法兰/接头的自动焊接。

This machine combines torque technology and dual-drive synchronous control, based on micro-arc characteristics, effectively solving the welding process technology for thin-walled Metal bellows and flanges. It is suitable for stainless steel, carbon steel, aluminum alloy, etc., with diameters ranging from 6mm to 450mm and wall thicknesses from 0.03mm to 2mm.

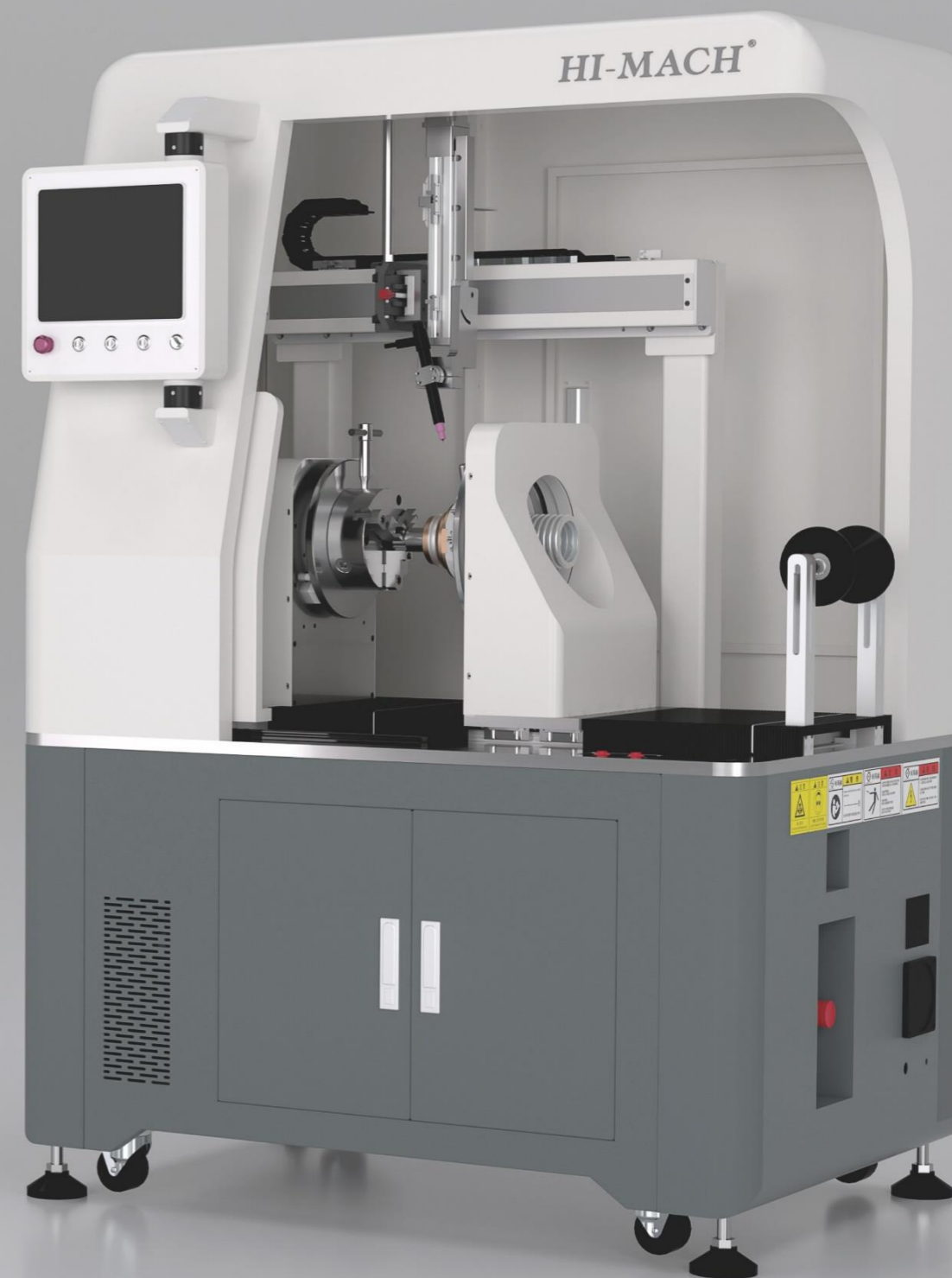

产品型号 Product name	焊接直径(mm) diameter range	焊接厚度(mm) Processing range	输出电流(A) Output Range	入力电压(V)/功率(KW) primary Volt/age(50-60Hz)	外形尺寸(mm) Dl dimensions H×W×D
ROBUST-ARC 06/ MIRCO	6-60	0.03-1	3-210/1-10	380/7.5	1100*750*1650
ROBUST-ARC 18	25-180	0.08-2	5-200	380/8.9	1280*910*1870
ROBUST-ARC 40	150-450	0.08-2	5-200	380/10.3	2010*1230*1980

软管焊接解决方案

ACCU-ARC



机械和控制系统等技术优势以及软管焊接工艺数据的支持，我们为软管自动焊接提供了前瞻性的工艺优化和自动化解决方案。采用先进的焊前成型技术替代传统的焊前扣压工艺，生产效率和焊接合格率提升了30%，简化了操作流程，同时提高了焊接品质。

We provide forward-looking process optimization and automation solutions for automatic hose welding, leveraging technical advantages in machinery, control systems, and supporting data on metal hose welding processes. We adopt advanced pre-weld forming technology to replace traditional pre-weld crimping processes, resulting in a 30% increase in production efficiency and welding qualification rate. This approach simplifies operational procedures while enhancing welding quality.

RIVET & WELDING

软管扣压和焊接

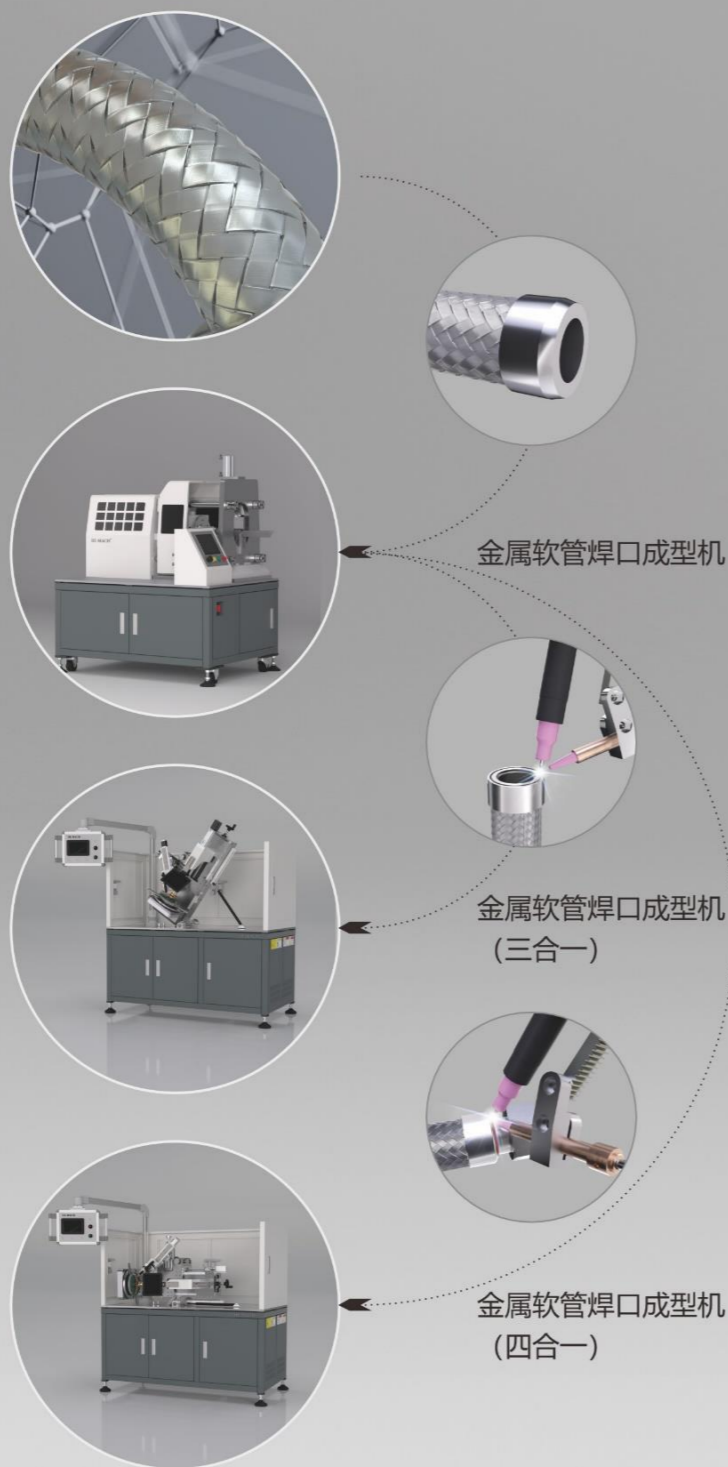



Hydraulic forming Machine



■ ROBUST 06/15 焊口成型机

- 在三合一金属软管的焊前加工中，焊口成型至关重要。波纹管、金属网和固定环在自由状态或扣压不一致时，无法符合自动化焊接的标准要求。利玛赫液压成型机完美解决了三合一软管的焊前管口成型一致性问题，为该类型产品实现自动化焊接提供了必要条件。适用：8mm-150mm三合一软管焊口成型。
- the pre-welding processing of three-in-one metal hoses, the shaping of the welding joints is crucial. When the bellows, metal mesh, and fixed rings are not in a consistent free state or clamped state, they cannot meet the standard requirements for automated welding. The HI-MACH hydraulic forming machine perfectly solves the issue of inconsistent shaping of welding joints in three-in-one hoses, providing the necessary conditions for achieving automated welding. Suitable for welding joint shaping of three-in-one hoses with diameters ranging from 8mm to 150mm.



产品型号 Product name	成型直径(mm) diameter range	压力范围(Tons) torque range	输入电压(V)/功率(KW) primary Volt/age(50-60Hz)	外形尺寸(mm) Dimensions H×W×D
ROBUST-06	8-60	0.5-10	380/11.2	1170*650*2200
ROBUST-10	20-100	2-35	380/15.5	1170*650*2200
ROBUST-15	50-150	2-60	380/20.3	1300*850*2200

Soft Welding Machine

三合一焊接



四合一焊接

自动翻转机架角度即可获得四合一软管焊接姿态
By automatically flipping the frame angle, a four-in-one hose welding position can be achieved.

■ ACU-ARC 06/15 C 软管焊接机

- 基于焊接技术研发生产的自动焊接机结合了HI-MACH VI STRUCTURE机构优势和AVC电弧控制技术，有效解决了三合一软管焊接的行业难题，为软管行业提供了高效的自动化利器。它轻松地完成了软管三合一的自动焊接，自动翻转机架角度即可获得四合一软管焊接姿态。
- Based on the advantages of the HI-MACH VI structure and AVC arc control technology, the industry challenges of three-in-one metal hose welding are effectively solved, providing the metal hose industry with a highly efficient automation tool. It easily accomplishes the automatic welding of three-in-one metal hose. By automatically flipping the frame angle, a four-in-one hose welding position can be achieved.

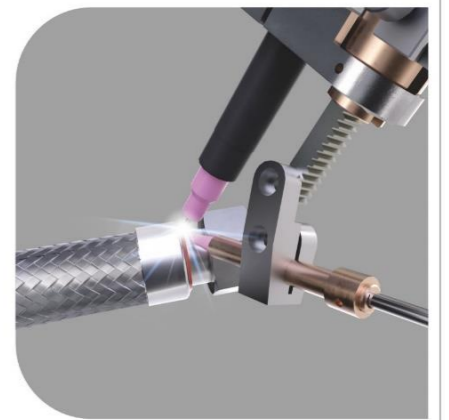

产品型号 Product name	焊接直径(mm) diameter range	焊接厚度(mm) Processing range	电流范围(A) Output Range	输入电压(V)/功率(KW) primary Volt/age(50-60Hz)	外形尺寸(mm) Dimensions H×W×D
ACU-ARC 06C	6-60	0.5-3	5-200	380/7.3	1230*850*1850
ACU-ARC 10C	20-100	0.5-3	5-230	380/9.8	1500*850*1850
ACU-ARC 15C	50-150	0.5-6	5-300	380/11.2	1500*900*1850

METAL BELLOWS
TRANSLATES & WELDING
焊接波纹管成型和焊接

公司致力于为焊接波纹管行业提供全流程自动化解决方案，包括冲压成型设备、焊接定位治具、内外圆自动焊接机以及焊后检测等一体化工艺流程。

Our company provides a full-process automation solution for the corrugated tube welding industry, with equipment including stamping forming equipment, welding positioning fixtures, and automatic inner and outer circle welding machines.



MIRCO-ARC系列微束焊接机将先进的微束电弧控制逻辑和HI-MACH VI STRUCTURE机构基础优势相结合，实现了0.03-0.5mm超精密波纹管膜片的自动焊接。

The MIRCO-ARC series welding machine combines micro-arc control logic to achieve automatic welding of ultra-precision corrugated tube films ranging from 0.03mm to 0.5mm.

MIRCO-ARC
焊接波纹管专机



Metal Bellows Translates Machine

■ CUT 48/100H 膜片冲压机

- 精密型伺服压力成型机采用液压系统对金属材料进行加工成型和切断。其采用伺服控制压力，具有高效率 and 稳定性的特点。480T-1000T 伺服压力控制可用于成型 6mm-800mm 的焊接波纹管膜片。
- The precision servo pressure forming machine uses a hydraulic system for processing and cutting metal materials. It features servo-controlled pressure for high efficiency and stability. The 480T-1000T servo pressure control can be used for forming metal bellows films ranging from 6mm to 800mm.



产品型号 Product name	成型直径(mm) diameter range	压力范围(Tons) torque range	切断能力(mm) cutting range	入力电压(V)/功率(KW) primary Volt/age(50-60Hz)	外形尺寸 Dimensions H×W×D
CUT 48H	6-260	10-480	0.03-0.2	380/22.8	1690*1660*2450
CUT 60H	100-450	20-600	0.1-0.6	380/45.5	1690*1660*2450
CUT 90H	200-800	50-900	0.2-1	380/92	1690*1660*2450

Metal Bellows Welding Machine



HI-MACH

■ MIRCO-ARC15/50H 内圆焊接机

- 精密四立柱快速组对波纹管膜片，采用高精度旋转支撑控制波纹管膜片跳动在 0.02mm 以内。配备 MIRCO TIG/PLASMA 实施自动焊接，焊缝美观，密封性能卓越。广泛应用于军工、航空航天、半导体、新能源汽车等行业焊接波纹管生产。
- Precision four-column fast assembly for metal bellows membranes, utilizing high-precision rotating support to control membrane flutter within 0.02mm. Equipped with MIRCO TIG/PLASMA for automatic welding of the membranes, resulting in aesthetically pleasing weld seams and excellent sealing performance. Widely used in the production of welded corrugated pipes in industries such as military, aerospace, semiconductor, and new energy vehicles.



产品型号 Product name	焊接直径(mm) diameter range	焊接厚度(mm) Processing range	电流范围(A) Output Range	入力电压(V)/功率(KW) primary Volt/age(50-60Hz)	外形尺寸(mm) Dimensions H×W×D
MIRCO-ARC 15H	12-150	0.06-0.5	1-15	220/11.2	1350*1050*1850
MIRCO-ARC 35H	150-350	0.06-0.5	1-15	220/11.8	1350*1050*1850
MIRCO-ARC 50H	300-500	0.12-2	3-200	220/9.5	1450*1280*1900



MIRCO-ARC 06/15L

外圆焊接机

HI-MACH VI STRUCTURE机构具有以下优势：高精度旋转支撑，能够实现整机的重复定位精度达到 $\pm 0.02\text{mm}$ 。同时，配备MIRCO TIG/PLASMA实现自动焊接，焊缝美观，密封性能卓越。

这种设备广泛应用于军工、航空航天、半导体、新能源汽车等行业的焊接波纹管生产。

Advantages of the HI-MACH VI STRUCTURE include a repeat positioning accuracy of $\pm 0.02\text{mm}$ for the entire machine achieved through high-precision rotating support. Equipped with MIRCO TIG/PLASMA for automated welding, it delivers aesthetically pleasing weld seams and outstanding sealing performance.

This equipment is widely used in the production of welded corrugated tubes in industries such as military, aerospace, semiconductors, and new energy vehicles.

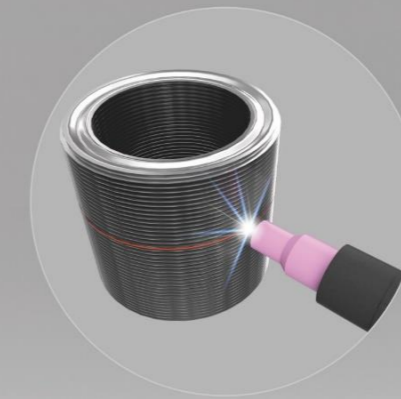

产品型号 Product name	焊接直径(mm) diameter range	焊接长度(mm) length range	焊接厚度(mm) Processing range	电流范围(A) Output Range	输入电压(V)/功率(KW) primary Volt/age(50-60Hz)	外形尺寸(mm) Dimensions H×W×D
MIRCO-ARC 06L	4-200	1-200	0.06-0.5	1-15	220/11.2	1550*1030*1850
MIRCO-ARC 10L	8-320	1-400	0.06-0.5	1-15	220/11.8	1550*1030*1850
MIRCO-ARC 15L	12-600	1-600	0.12-2	3-200	220/9.5	2400*1450*2000

传感器产品焊接

SENSOR WELDING MACHINE

我们致力于为客户提供完整的生产设备和技术服务，专注于解决仪器、仪表和传感器行业的自动化和焊接需求。

We provide customers with complete production equipment and technical services to meet their needs.

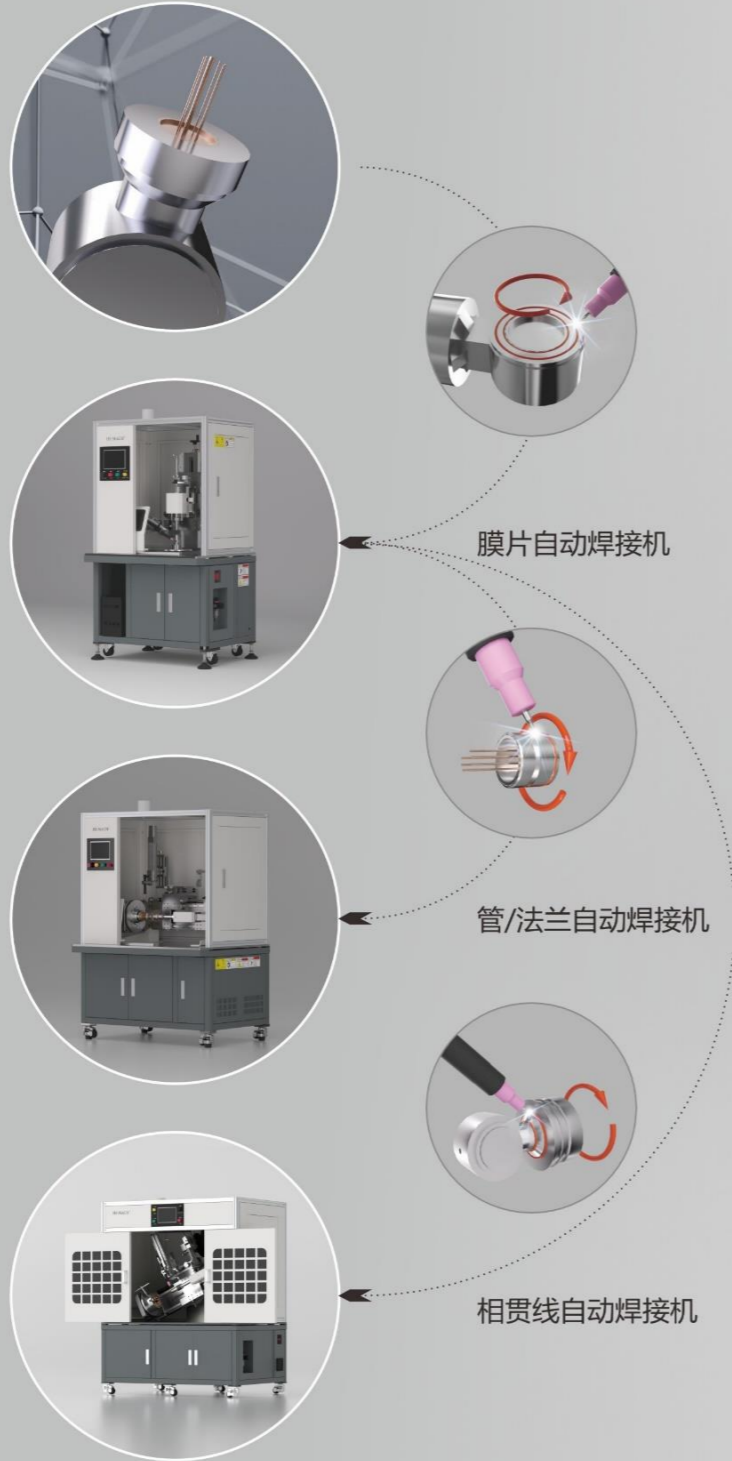

提供多类型的仪器、仪表和传感器行业的自动焊接单机和自动化生产线，设备应用于膜片、法兰、直管、弯管、VCR接头、壳体、盖板和导线的焊接和组装。

We produce a variety of automatic welding machines and automated production lines or instruments, meters, and sensors, used for welding and assembly of membranes, flanges, straight tubes, bent tubes, VCR connectors, housings, covers, and wires.

仪表类自动焊接解决方案

ACCURARC

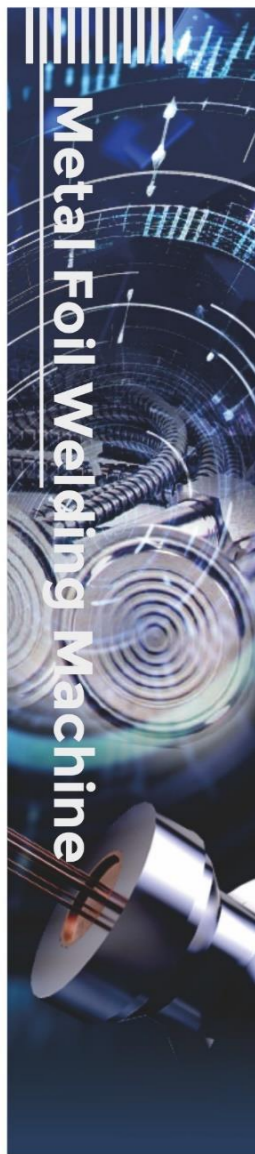

Metal Foil Welding Machine



■ ACU-ARC 06/10V 膜片自动焊接机

- ACU-ARC微束技术微电流特性卓越，精密的机械结构和软件优势将整机重复定位精度控制在±0.02mm以内，本机已成功应用于超过500套仪器，仪表行业案例。解决0.01mm至1mm范围内各种超薄金属压膜片的焊接难题。
- ACU-ARC micro-beam welding technology employs precise mechanical structure and software, with the entire machine's repeat positioning accuracy controlled within ±0.02mm. This machine has been successfully applied in over 500 industry cases. It is used for welding various ultra-thin metal pressure membrane films within the range of 0.01mm to 1mm.

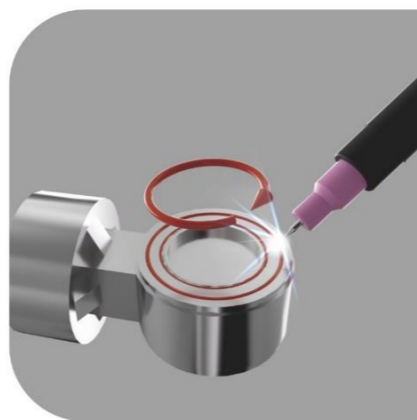

产品型号 Product name	焊接直径(mm) diameter range	焊接行程(mm) length range	焊接厚度(mm) Processing range	电流范围(A) Output Range	入力电压(V)/功率(KW) primary Volt/age(50-60Hz)	外形尺寸(mm) Dimensions H×W×D
ACU-ARC 06V/MIRCO	3-120	8-300	0.01-0.5	1-210/1-10	220/11.2kw	1100*850*1800
ACU-ARC 10V/MIRCO	8-320	8-400	0.06-1	1-210/1-10	220/11.8KW	1100*850*1800

Tube/Flange Welding Machine



■ ACU-ARC 06/16L 管/法兰自动焊接机

- ACU-ARC 06/16L 自动焊接机用于仪表的膜片、法兰、管件和本体的焊接，L型水平机构给产品上下料提供了足够的空间，四轴联动，配有气动尾顶控制焊接变形和组对位移。
- The ACU-ARC 06/16L automatic welding machine is used for welding membranes, flanges, tube fittings, and bodies of instruments. Its L-shaped horizontal structure provides ample space for loading and unloading of products, with four-axis linkage and equipped with pneumatic tailstock to control welding deformation and component displacement.



产品型号 Product name	焊接直径(mm) diameter range	焊接行程(mm) length range	焊接厚度(mm) Processing range	电流范围(A) Output Range	入力电压(V)/功率(KW) primary Volt/age(50-60Hz)	外形尺寸(mm) Dimensions H×W×D
ACU-ARC 06L/MIRCO	4-160	10-200	0.5-3/0.03-0.5	3-210/1-10	220/9.2KW	1260*940*1800
ACU-ARC 10L/MIRCO	8-240	1-400	0.5-3	5-200/1-10	220/9.8KW	1260*940*1800
ACU-ARC 16L/MIRCO	16-320	1-600	0.5-6	5-300/1-10	220/11.2KW	1400*1000*1800



ACU-ARC 06/16R

相贯线自动焊接机

六轴联动控制工作轨迹有圆周，直线和插补，能实现行程范围内任意圆周轨迹自动焊接，HI-MACH R型架构-5°--130°整机自动翻转，可在焊接过程中依据焊接姿态需求自动翻转变位。

这种设备广泛应用于军工、航空航天、半导体、新能源汽车等行业仪器仪表的生产。

The six-axis coordinated control allows for circular, linear, and interpolation work trajectories, enabling automatic welding of any circular trajectory within the working range. The HI-MACH R-type architecture offers automatic flipping of the entire machine within a range of -5° to 130°, allowing for automatic flipping and positioning adjustments based on welding posture requirements during the welding process.

This equipment is widely used in the production of instruments and meters in industries such as military, aerospace, semiconductors, and new energy vehicles.

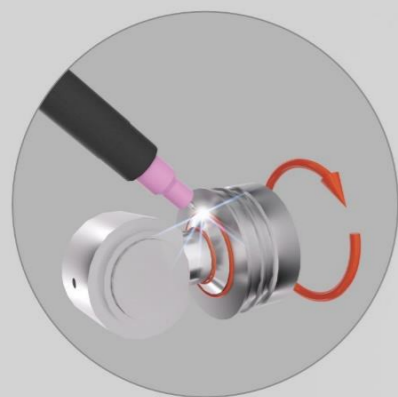

产品型号 Product name	焊接直径(mm) diameter range	焊接行程(mm) length range	焊接厚度(mm) Processing range	电流范围(A) Output Range	入力电压(V)/功率(KW) primary Volt/age(50-60Hz)	外形尺寸(mm) Dimensions H×W×D
ACU-ARC 06R/MIRCO	4-160	1-240	0.5-3/0.03-0.5	3-210/1-10	220/9.2	1100*850*1830
ACU-ARC 10R/MIRCO	8-240	1-400	0.5-3	5-200	220/9.8	1450*1050*1850
ACU-ARC 15R/MIRCO	16-320	1-600	0.5-6	5-300	220/11.2	1640*1260*2250

定制类自动焊接机

Customized fully automated welding solutions

■ ETR焊接机

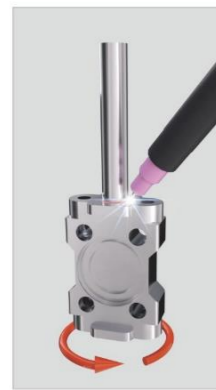

ETR无限回转技术，三轴联动控制，配备MIRCO TIG焊枪可在狭小的空间内实施圆周或曲线的自动焊接。特殊工装夹具解决方案可在12mm空间内实施焊接。

The ETR infinite rotation technology, combined with three-axis coordinated control and equipped with a MIRCO TIG welding gun, enables automatic welding of circular or curved joints in confined spaces. Special tooling solutions allow welding to be carried out within a 12mm space.



■ 平台焊接机

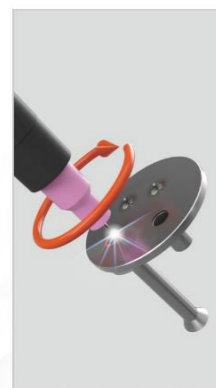

平台两轴平稳高精度的运动控制和焊枪三轴运动控制器，能实施工作范围内任意点位和线性焊接。产品设计了快速夹具，以确保零件准确地呈现给精密Tig焊接。HI-MACH V5.0控制系统用于创建和存储无限运动和焊接容量的配方。

The platform features two-axis smooth high-precision motion control and a three-axis motion controller for the welding gun, allowing for arbitrary point and linear welding within the working range. The product is designed with quick clamping fixtures to ensure accurate presentation of parts to the precision Tig welding. The HI-MACH V5.0 control system is used to create and store unlimited motion and welding recipes.



■ 双工位焊接机



双工位交替焊接工作平台利于高效率装卸产品，自动进出料机构提升了50%工作效率，HI-MACH V5.0+控制系统用于创建和存储高效率运动和焊接的配方。

The dual-welding work platform facilitates efficient loading and unloading of products, while the automatic feeding and unloading mechanism increases work efficiency by 50%. The HI-MACH V5.0+ control system is used to create and store recipes for efficient motion and welding.

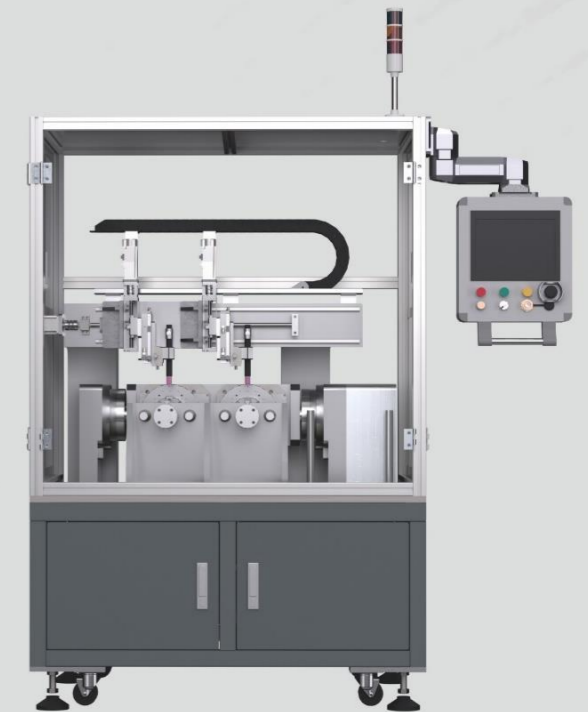

■ 旋转多工位焊接机



旋转多工位自动机是一种用于自动化生产的设备，具有多个工位，可同时进行多个工序。该设备通常采用旋转式结构，工件会依次转移到不同的工位进行加工或装配。这种设备能够提高生产效率，减少人力成本，广泛应用于各种生产线上，特别适用于需要连续完成多道工序的生产场景。

The rotating multi-station automatic machine is a type of equipment used for automated production, featuring multiple workstations for simultaneous processing of multiple operations. Typically designed with a rotating structure, workpieces are sequentially moved to different workstations for processing or assembly. This equipment can enhance production efficiency, reduce labor costs, and is widely used in various production lines, especially suitable for production scenarios requiring the continuous completion of multiple operations.





ROBUST-ARC/B

切焊一体机

HI-MACH VI STRUCTURE机构具有以下优势：高精度旋转支撑，能够实现整机的重复定位精度达到±0.02mm。同时，配备MIRCO TIG/PLASMA实现自动焊接，焊缝美观，密封性能卓越。

这种设备广泛应用于军工、航空航天、半导体、新能源汽车等行业仪器仪表的生产。

Advantages of the HI-MACH VI STRUCTURE include a repeat positioning accuracy of ±0.02mm for the entire machine achieved through high-precision rotating support. Equipped with MIRCO TIG/PLASMA for automated welding, it delivers aesthetically pleasing weld seams and outstanding sealing performance.

This equipment is widely used in the production of instruments and meters in industries such as military, aerospace, semiconductors, and new energy vehicles.

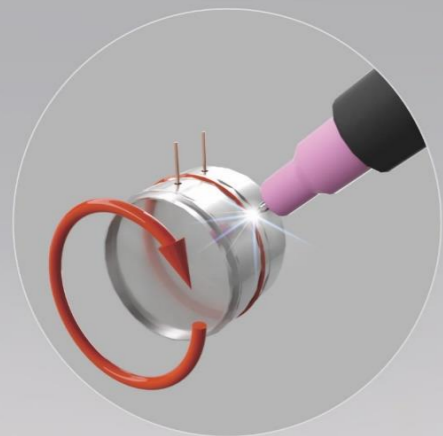

管/法兰自动焊接解决方案

MACT-ARC

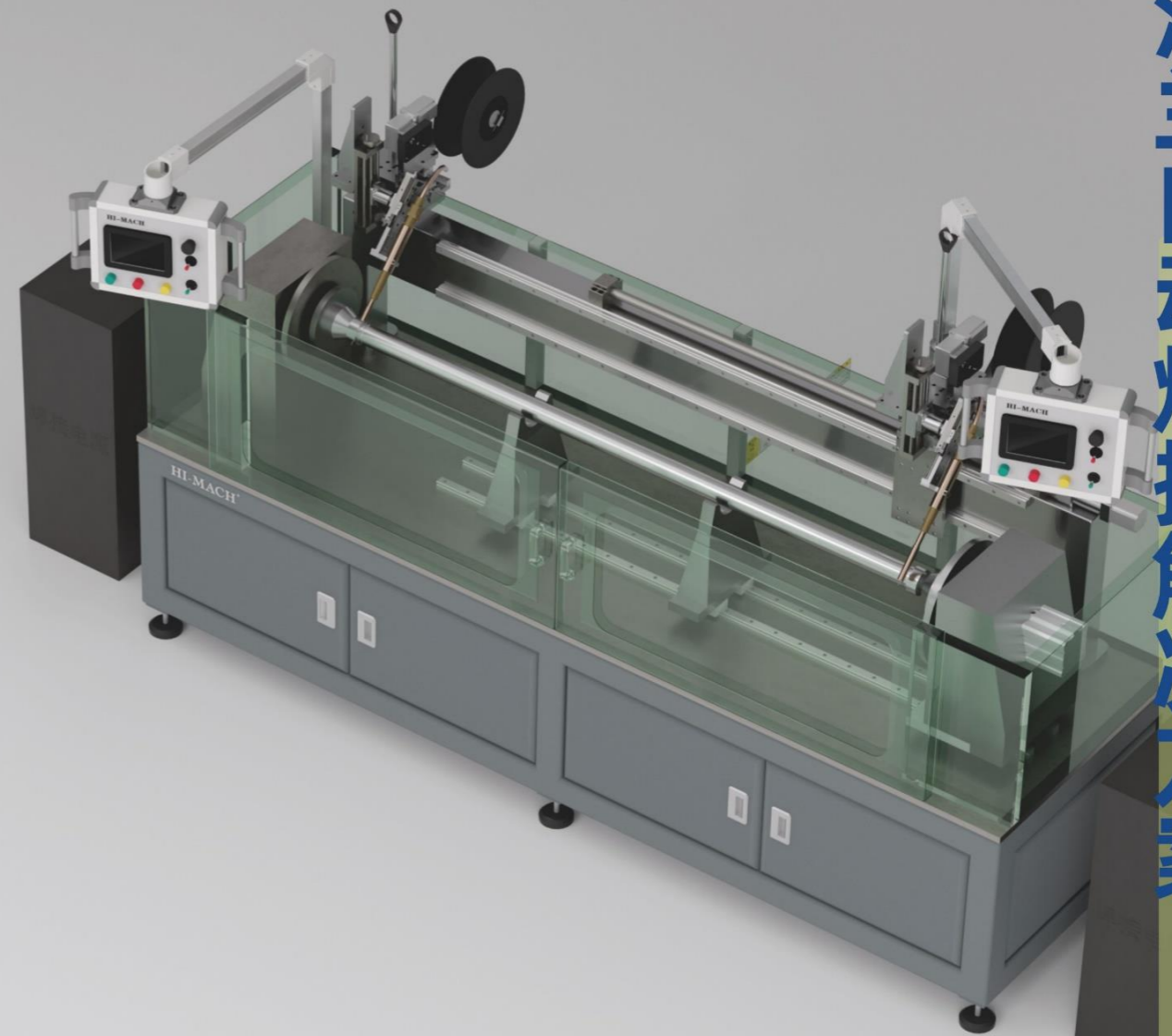

用于直径4mm-800mm，厚度1mm-12mm的碳钢、不锈钢、铜、铝、合金和特材的焊接。搭载GMAW、GTAW、PAW、LBW等多种焊接方式。

It is used for welding carbon steel, stainless steel, copper, aluminum, alloy and special materials with diameter of 4mm-800mm and thickness of 1mm-12mm. It is equipped with various welding methods such as GMAW, GTAW, PAW, LBW, etc.

两轴到十轴的丰富配置区间，为用户提供最优的自动化焊接解决方案。

The rich configuration range from two axes to ten axes provides users with the best automated welding solutions.

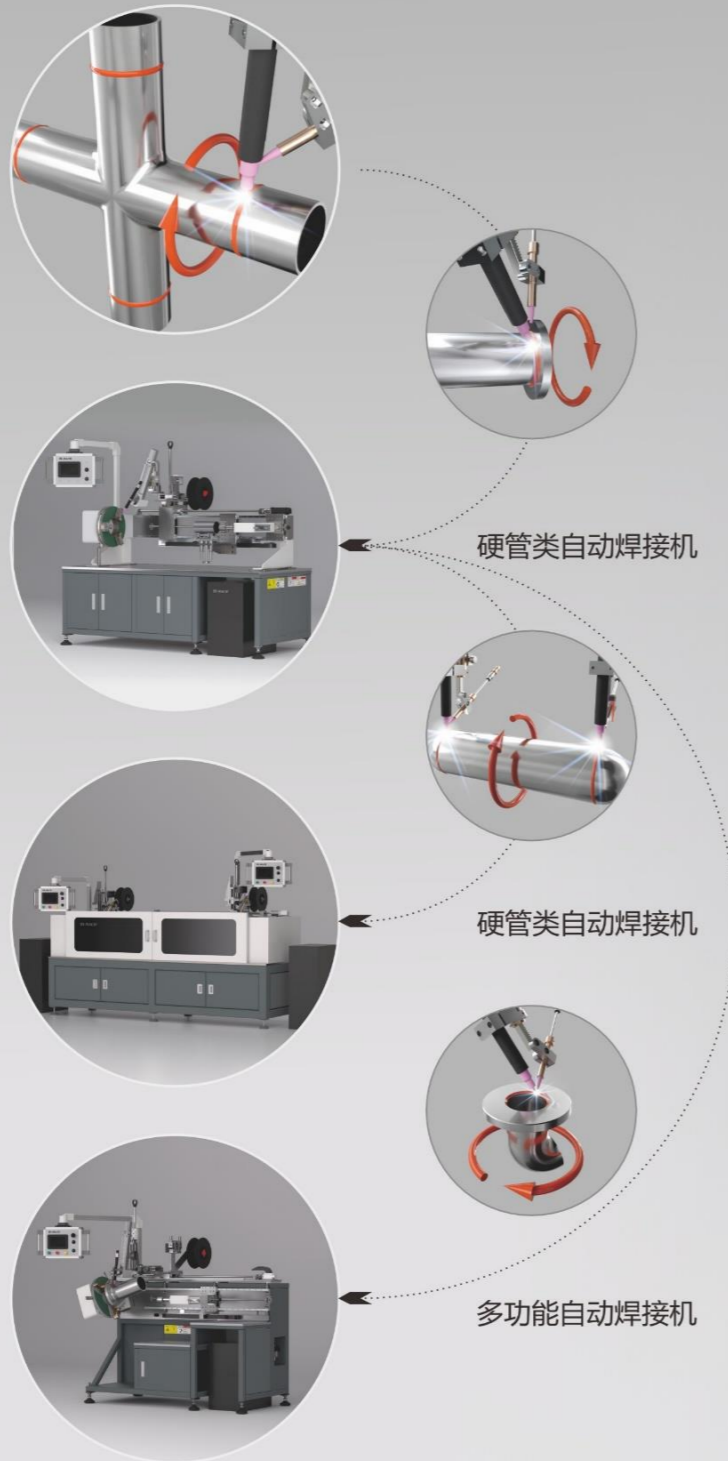

TUBE & FLANGE WELDING MACHINE

管/法兰自动焊接机



Tube & Flange Welding Machine

■ HI-ARC 06/22L 硬管类自动焊接机

- 用于直径4mm-680mm，厚度0.8mm-6mm，长度10mm-1200mm的管管，管法兰，管弯头和桶体的自动焊接。可搭载GMAW、GTAW、PAW、LBW等多种焊接电源，满足碳钢、不锈钢、铜、铝、合金和特材的多种焊接工艺要求。
- Designed for automatic welding of tubes, tube flanges, tube elbows, and barrel bodies with diameters ranging from 4mm to 680mm, thicknesses between 0.8mm and 6mm, and lengths from 10mm to 1200mm. It can be equipped with various welding power sources such as GMAW, GTAW, PAW, LBW to meet the welding process requirements of carbon steel, stainless steel, copper, aluminum, alloys, and special materials.

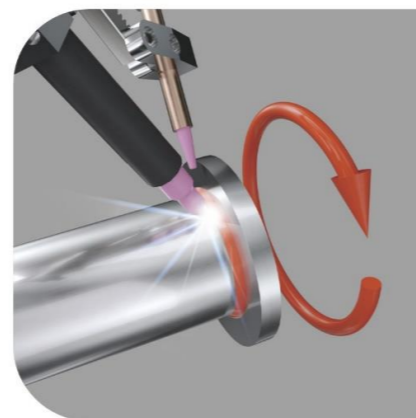

产品型号 Product name	焊接直径(mm) diameter range	中空直径(mm) max range	电流范围(A) Output Range	焊接厚度(mm) Processing range	最大承载(kg) Max tube weight	入力电压(V)/功率(KW) primary Volt/age(50-60Hz)	外形尺寸(mm) Dimensions H×W×D
HI-ARC 06L	4-160	62	5-200	0.8-3	50	220/7.8KW	1250*700*1600
HI-ARC 15L	20-400	150	5-300	1-5	100	380/9.8KW	1550*900*1820
HI-ARC 22L	50-680	210	5-400	1-6	200	380/11.2KW	2000*900*1820

Tube & Flange Welding Machine

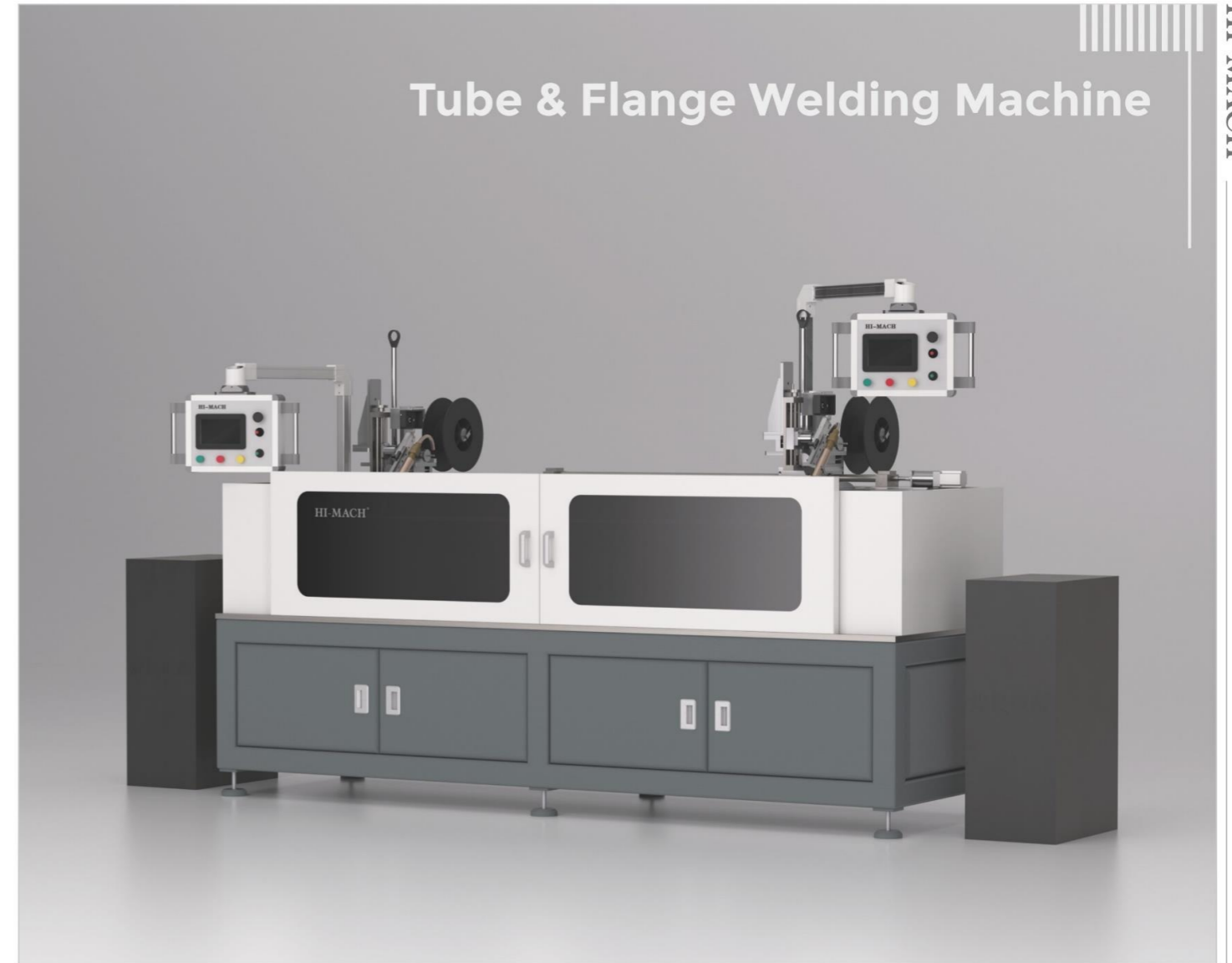

HI-MACH®

■ MACH-ARC 15/35L 硬管类自动焊接机

- 用于直径20mm-800mm，厚度2mm-16mm，长度400mm-6000mm的管管，管法兰和桶体的自动焊接。可搭载GMAW、GTAW、PAW、LBW等多种焊接电源，满足碳钢、不锈钢、铜、铝、合金和特材的多种焊接工艺要求。
- Designed for automatic welding of tubes, tube flanges, and barrel bodies with diameters ranging from 20mm to 800mm, thicknesses between 2mm and 16mm, and lengths from 400mm to 6000mm. It can be equipped with various welding power sources such as GMAW, GTAW, PAW, LBW to meet the welding process requirements of carbon steel, stainless steel, copper, aluminum, alloys, and special materials.

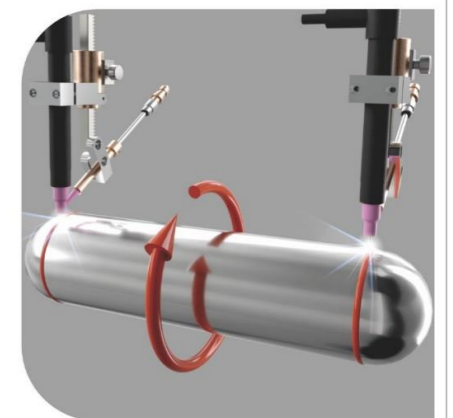

产品型号 Product name	焊接直径(mm) diameter range	中空直径(mm) max range	电流范围(A) Output Range	焊接厚度(mm) Processing range	焊接长度(mm) length range	最大承载(kg) Max tube weight	入力电压(V)/功率(KW) primary Volt/age(50-60Hz)	外形尺寸(mm) Dimensions H×W×D
MACH-ARC 15L	20-460	150	5-350	2-16	400-2000	500	380/7.8KW	2400*900*1800
MACH-ARC 22L	200-650	220	5-450	2-16	800-3600	1000	380/9.8KW	4000*1000*1850
MACH-ARC 35L	400-800	350	5-450	2-16	1200-6000	2000	380/11.2KW	6500*1000*1950



ACU-ARC 10-22R

多功能自动焊接机

适用于直径10mm至800mm，厚度1mm至16mm的碳钢、不锈钢、铜、铝、合金和特殊材料的焊接。该机器配备了多种焊接方式，包括GMAW、GTAW、PAW、LBW等。采用六轴联动控制，确保焊接操作精确高效。

这款先进的自动焊接系统具有高度灵活性和自动化能力。

DSuitable for welding carbon steel, stainless steel, copper, aluminum, alloys, and special materials with diameters ranging from 10mm to 800mm and thicknesses between 1mm and 16mm. The machine is equipped with various welding methods including GMAW, GTAW, PAW, LBW. Utilizing six-axis coordinated motion control ensures precise and efficient welding operations.

This advanced automatic welding system features high flexibility and automation capabilities.

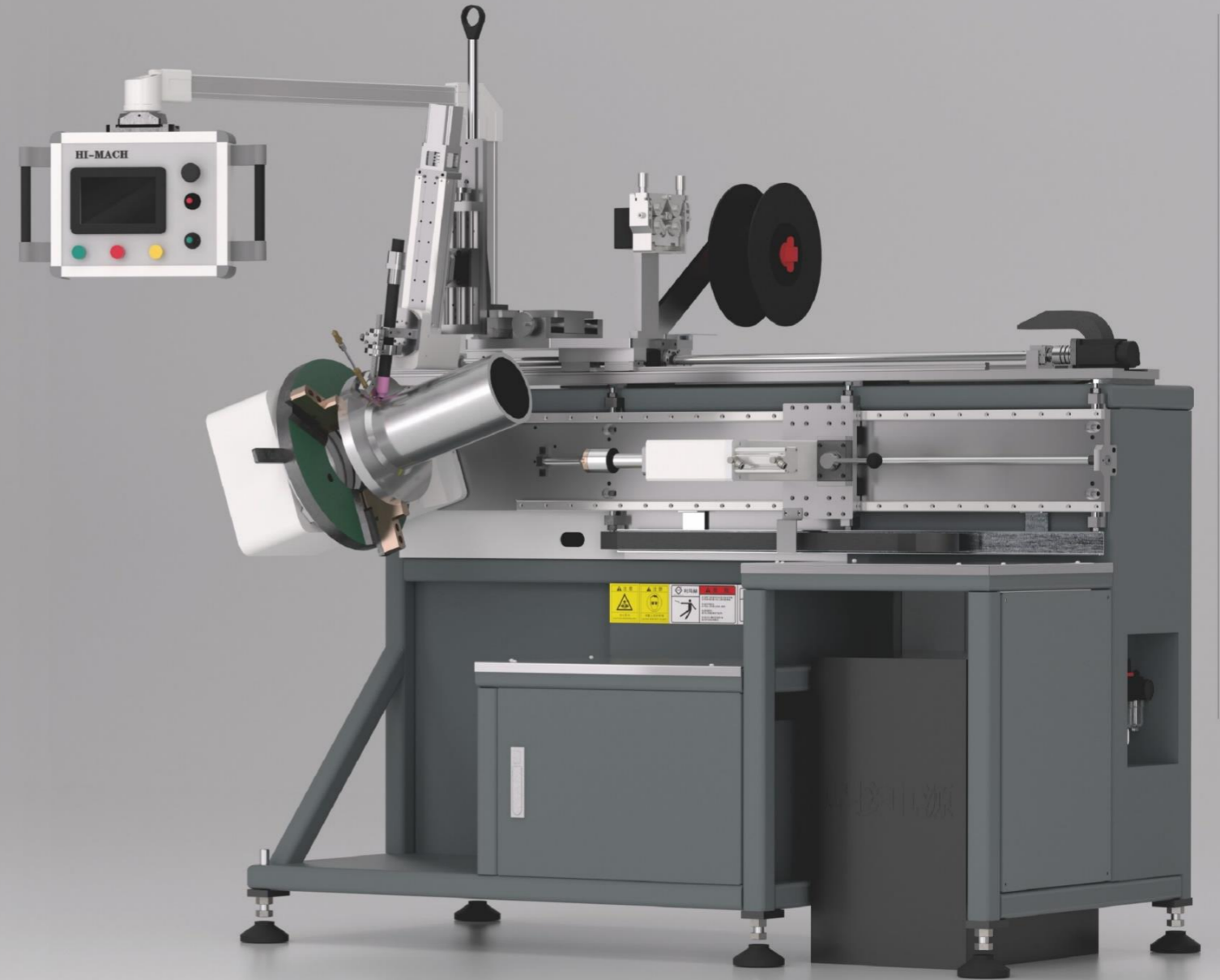
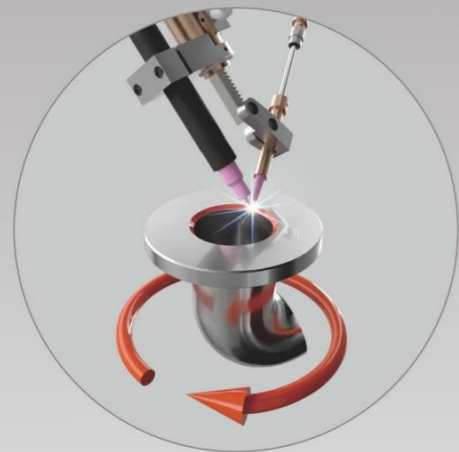

产品型号 Product name	焊接直径(mm) diameter range	中空直径(mm) max range	电流范围(A) Output Range	焊接厚度(mm) Processing range	焊接长度(mm) length range	最大承载(kg) Max tube weight	输入电压(V)/功率(KW) primary Volt/age(50-60Hz)	外形尺寸(mm) Dlimentions H×W×D
ACU-ARC 10R	10-420	100	5-300	1-6	10-600	100	380/14	1450*1000*1800
ACU-ARC 17R	20-600	170	5-450	2-16	20-1000	300	380/19.8	1700*950*1800
ACU-ARC 22R	50-800	220	5-450	2-16	50-1600	500	380/28.3	1900*1200*1900

管类自动焊接机定制

Custom Fully Automatic Tube Welding Machine

定制全自动焊接解决方案，定制类型包含真空仓自动上料机构、下料机构、组对机构、检测系统、焊接系统等全自动化焊接流程和工艺技术服务。

We offer full-automatic welding solutions, customized to include vacuum chamber automatic feeding mechanisms, unloading mechanisms, pairing mechanisms, inspection systems, welding systems, and other fully automated welding processes and technical services.

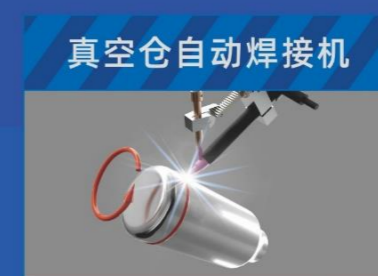

直缝类自动焊接机

Automatic Longitudinal Seam Welding Machine

定制直缝类料厚0.6mm-3mm的料带对接机，直缝焊接机，自剪板下料、焊口剪切、卷料成型、自动上料、自动焊接和自动下料的单机，直缝焊接的整套生产线体以及生产工艺技术服务。

Customized straight seam material strip butt jointing machine with thickness of 0.6mm-3mm, straight seam welding machine, self-shearing plate unloading, weld shearing, coil forming, automatic loading, automatic welding and automatic unloading single machine and straight seam welding complete production line and production process technical services.

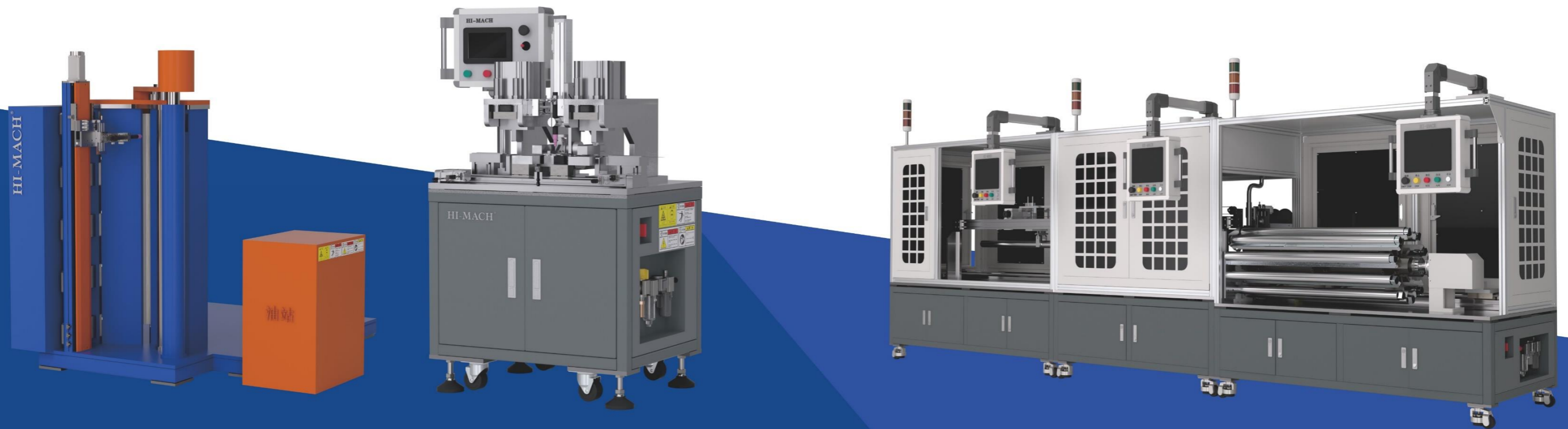

立式直缝焊机

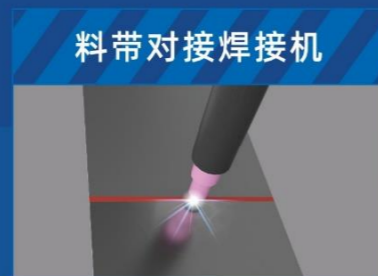

料带对接焊机

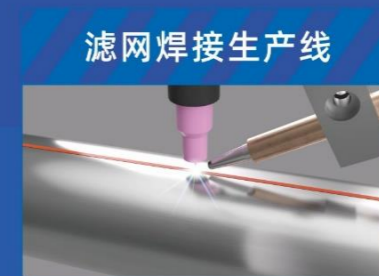

滤网焊接生产线

在线阀门堆焊系统

Online Valve Overlay Welding System

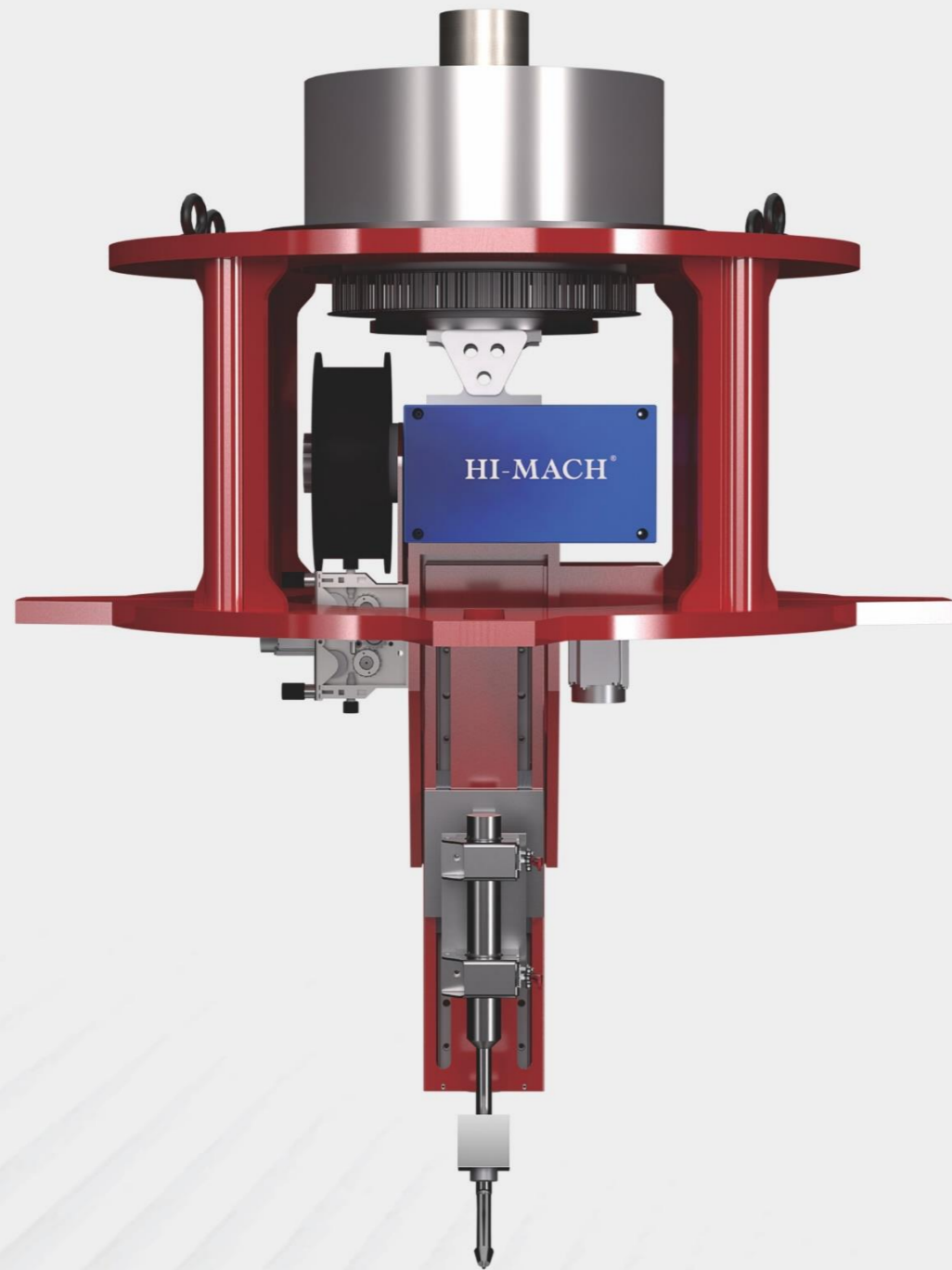

系统集成

堆焊自动化

Surface Multifunctional Cladding Welding Equipment

应用场景

利玛赫自动化堆焊系统广泛应用于冶金设备、电力系统、航空航天、石油化工等行业。

The Limax automatic overlay welding system is widely used in industries such as metallurgical equipment, power systems, aerospace, and petrochemicals.

▼ 辊轴堆焊系统
Roll Overlay Welding System

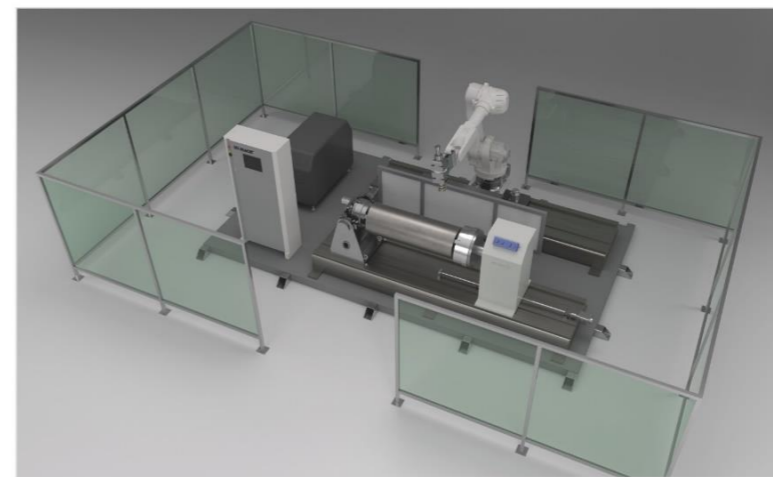
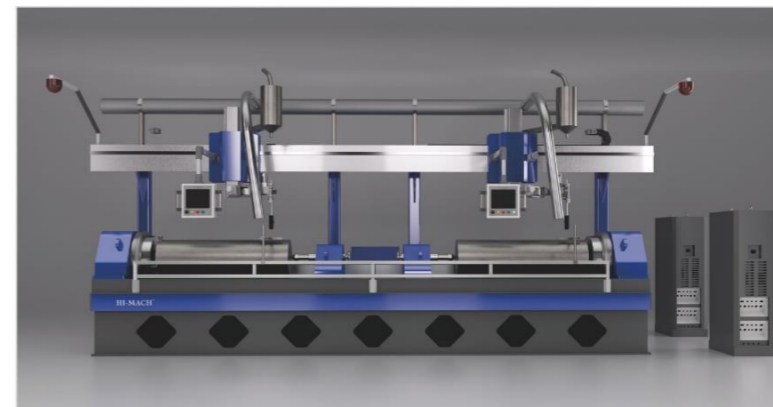

▲ 激光熔覆堆焊系统
Laser Cladding Overlay Welding System

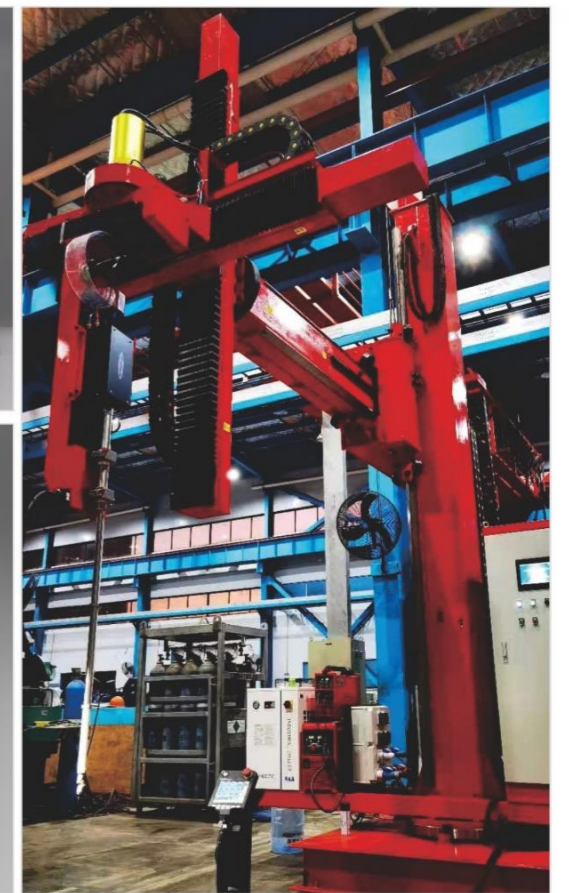

▲ 热丝堆焊系统
Hot Wire Overlay Welding System

提供先进的堆焊自动化解决方案、堆焊自动化设备、系统集成和技术支持。我们的系统涵盖辊轴堆焊、在线阀门堆焊、热丝堆焊和激光熔覆堆焊等类型，这些系统广泛应用于冶金设备、电力系统、航空航天、石油化工等行业。

我们利玛赫自动化致力于为客户提供高品质、可靠的堆焊自动化解决方案，满足客户个性化需求。

We provide advanced automated welding solutions, welding automation equipment, system integration, and technical support in the field of automated welding. Our systems cover various types including roller welding, online valve welding, hot wire welding, and laser cladding welding. These systems are widely used in industries such as metallurgical equipment, power systems, aerospace, and petrochemicals.

LIMAH Automation is committed to providing customers with high-quality, reliable automated welding solutions to meet their individualized needs.

机器人电机定子焊接系统 Robot Motor Stator Welding System



机器人系统集成 Robot System Integration

应用场景

利玛赫机器人集成系统广泛应用于冶金设备、电力系统、航空航天、石油化工等行业。

The Limax robotic integration system is widely used in industries such as metallurgical equipment, power systems, aerospace, and petrochemicals.

▼ 机器人轴销垫板焊接系统
Robot Shaft Pin Pad Welding System



▼ 机器人阀体堆焊系统
Robot Valve Body Overlay Welding System

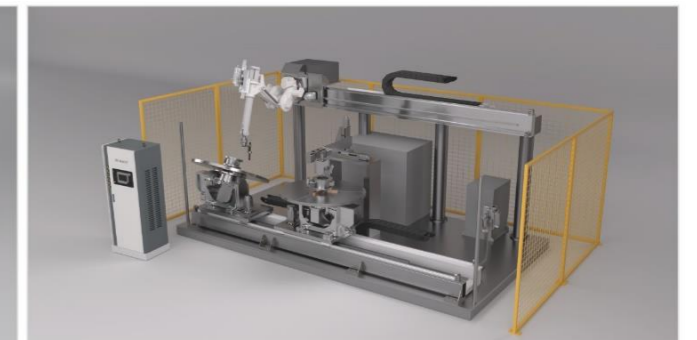

▲ 机器人集水管焊接系统
Robot Header Pipe Welding System



▲ 机器人电机定子焊接系统
Robot Motor Stator Welding System



利玛赫自动化科技有限公司集成机器人焊接系统技术优势突出，采用先进的机器人技术和高效的焊接设备，实现高精度、高效率的焊接任务处理。我们灵活的系统集成方案能够满足客户个性化需求，智能化的自动化控制确保生产可靠稳定。

专业的技术支持和培训服务确保客户能够熟练操作和维护系统。选择利玛赫，选择高品质、高效率的机器人焊接解决方案！

HI-MACH Automation Technology Co., Ltd. excels in integrated robot welding systems, utilizing advanced robot technology and efficient welding equipment to achieve high precision and productivity in welding tasks. Our flexible system integration solutions cater to individual customer needs, while intelligent automation control ensures reliable and stable production. Professional technical support and training services enable customers to operate and maintain the system proficiently.

Choose HI-MACH for high-quality, high-efficiency robot welding solutions!"

研发生产高效率自动化设备线

Customized fully automated welding solutions

以产品品质和产能为中心，结合公司技术优势设计，研发生产高效率自动化设备线体包含组装、运载、检测、焊接、加工、包装等人工智能系统。

Focusing on product quality and production capacity, combined with the company's technological advantages, we design, develop and produce high-efficiency automated equipment lines including assembly, transportation, testing, welding, processing, packaging and other artificial intelligence systems.

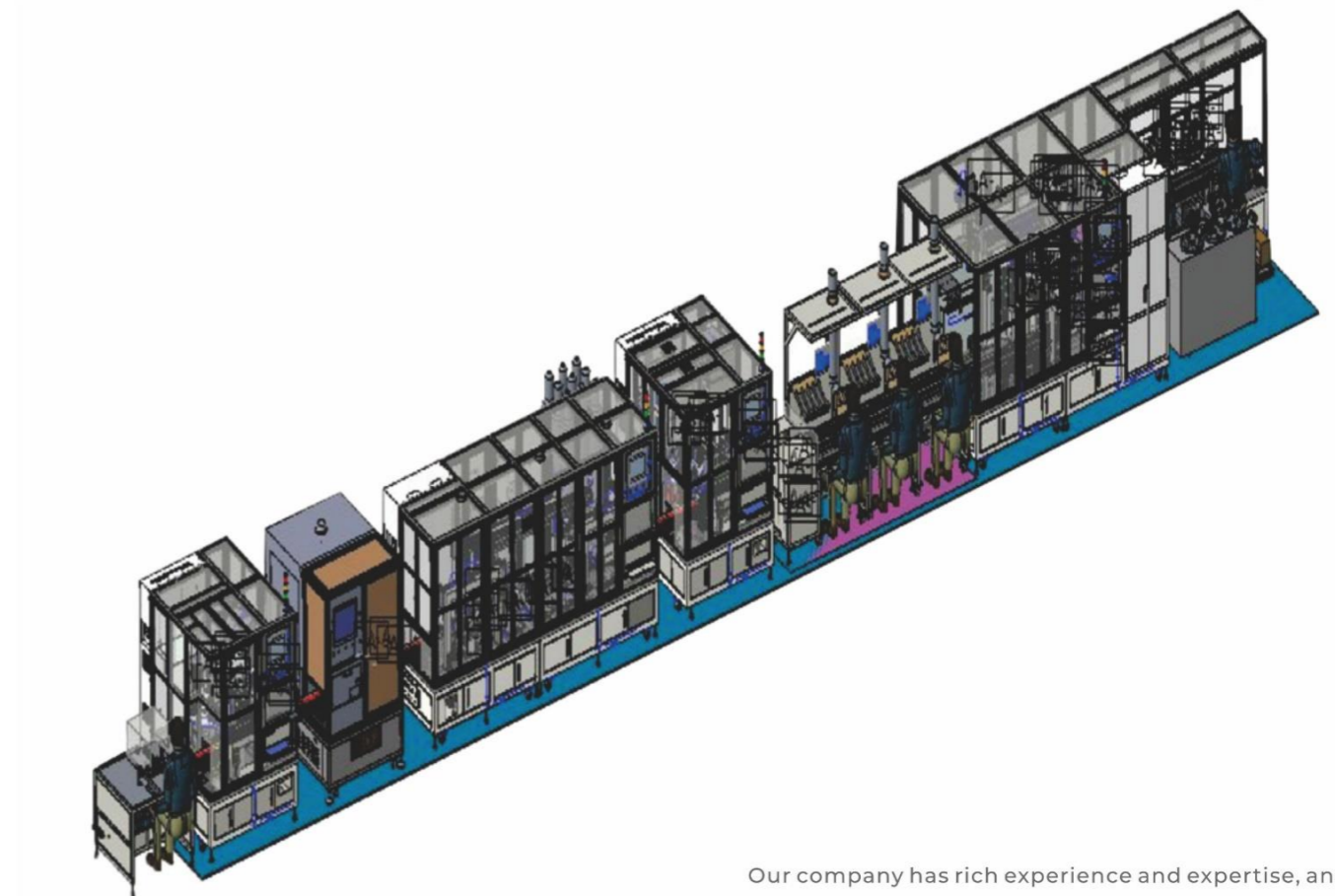
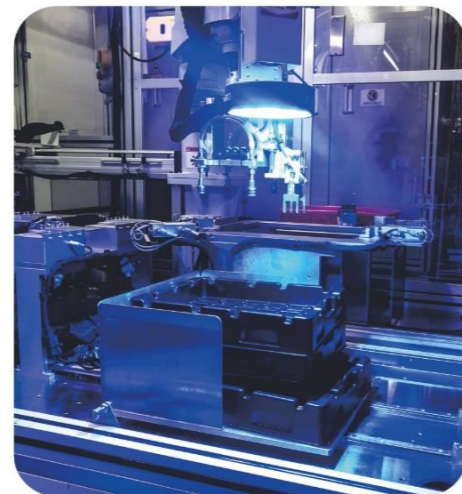

我们公司拥有丰富的经验和专业知识，可以为您提供研发、设计和生产全自动智能流水线的服务。我们可以根据您的产品需求和生产流程，为您定制自动上料、检测、组装、组对、焊接、移栽、外观检测、尺寸检测、压力检测等全自动智能设备，并实现产品的搬运、组对、焊接、检测、移栽、组装、打标、包装、堆叠等流程的智能自动化流程。我们将充分整合项目集成，确保设备符合您的生产需求并达到您的预期效果。

Our company has rich experience and expertise, and can provide you with services for R&D, design and production of fully automatic intelligent assembly lines. We can customize fully automatic intelligent equipment such as automatic feeding, testing, assembly, grouping, welding, transplanting, appearance inspection, size inspection, pressure inspection, etc. according to your product requirements and production processes, and realize the intelligent automation process of product handling, grouping, welding, testing, transplanting, assembly, marking, packaging, stacking and other processes. We will fully integrate project integration to ensure that the equipment meets your production needs and achieves your expected results.

TECHNOLOGY LEADERSHIP

技术引领

项目规范

项目时

其他

不断进化 ∞

专于技 匠于心 品于行

LI-MACH

自主研发 突破垄断

先进自动焊接整体解决方案提供商

技术团队

Our Technical Team

利玛赫与知名企业及科研机构展开合作，共同推动技术发展，共同攻克技术难题，突破行业垄断，自主研发创新产品，致力于成为行业中的领导者，通过不断创新和引领，以实现在行业中的领先地位。

Cooperate with well-known enterprises and scientific research institutions to jointly promote technological development, jointly overcome technical problems, break through industry monopoly, and independently develop innovative products. Committed to becoming a leader in the industry, through continuous innovation and leadership, in order to achieve a leading position in the industry.

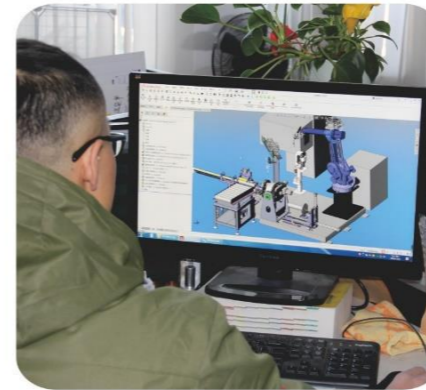

■ MACHANNICAL DESIGN 结构工程师

- 本科学历，平均设计经验为8-10年；机械设计软件平台Inventor, AutoCAD, Solid works 和仿真模拟软件Robot Studio 6.2。
Bachelor's degree with an average of 8-10 years of design experience; proficient in mechanical design software platforms such as Inventor, AutoCAD, SolidWorks, and simulation software Robot Studio 6.2.



■ ELECTRICAL DESIGN 电气工程师

- 本科学历，平均设计经验为6-8年；电气设计遵循IEC-61131标准；电气设计软件平台E-plan；软件平台TIA Portal, Twincat, OPCON。
Bachelor's degree with an average of 6-8 years of design experience; electrical design following the IEC-61131 standard; proficient in electrical design software platforms such as E-plan; software platforms include TIA Portal, Twincat, OPCON.



■ TEST ENGINEER 测试工程师

- 软件质量的把关者。
The gatekeeper of software quality.
- 10年以上行业经验，精通LABVIEW, VB, C++等软件。现场调试，本科学历，3-5年现场调试经验。
Over 10 years of industry experience, proficient in software such as LABVIEW, VB, C++; on-site debugging expertise; Bachelor's degree with 3-5 years of on-site debugging experience.

专利资质 QUALIFICATIONS AND HONORS



公司致力于行业内设备的研发，积极开展与院校和机构合作探索，在多个领域和项目有所突破且通过机构的认定获得资质证书。公司成立至今一直不断的投入新产品的研发，至今为止获得实用和发明专利已超过100项。

The company is dedicated to the research and development of industry equipment, actively engaging in collaborative explorations with academic institutions and organizations. It has achieved breakthroughs in multiple fields and projects, and has obtained qualification certificates through organizational recognition. Since its establishment, the company has continuously invested in the development of new products and has obtained over 100 utility and invention patents to date.