

Remote Process Actuation Control System AirLINE - Rockwell Point I/O System

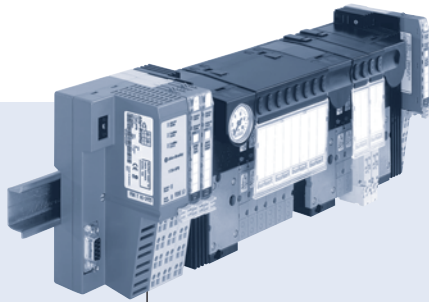

- Fully compatible with Rockwell Point I/O System
- Combination of Fieldbus, pilot valves and I/O modules
- High flexibility
- Compact design
- High flow rate

Type 8644 can be combined with...



Type 8175
Sensors

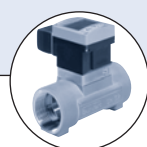

Type 8032
Switches

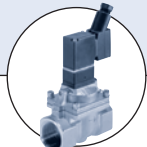

Type 6212
Solenoid valves

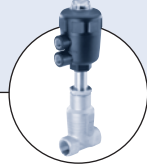

Type 2012
Process valves

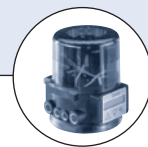

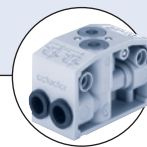

Type 8630
Valve controllers





Type 0498
Double pilot controlled check valve

The AirLINE System integrates high performance solenoid pilot valves, remote electronic I/O and fieldbus communication into a process actuation and control system that is both compact and extremely flexible. Its modular design allows fully customized, pre-mounted and tested solutions to exactly

meet all application needs including the integration of a local Mini PLC. Due to the full electronic and mechanical integration, the valve block can be added without the need of any tools or wiring.

Specifications	Pilot valve type	
	0460, 6524, 6525 	0461, 6526, 6527 
Mounting dimensions	11 mm	16.5 mm
Circuit functions/ways	C (3/2) D (3/2) H (5/2) H (5/2) impulse L (5/3) in middle position all ports closed N (5/3) in middle position all ports vented	C (3/2) D (3/2) H (5/2) H (5/2) impulse L (5/3) in middle position all ports open N (5/3) in middle position all ports vented
Flow rate	300 l/min (200 l/min for functions H impulse, L and N)	700 l/min (500 l/min for functions H impulse, L and N)
Pressure range	Vac. up to 10 bar	Vac. up to 10 bar
Module types	2x and 8x (optional integrated check valves and p-shut-off-valve)	2x and 4x (optional integrated check valves) Combination of 11 mm modules (3 valves) and 16.5 mm modules is possible
Max. number of modules	13	13
Max. number of valves functionalities	64 (by use of Type 0460 & Type 6524 2 x 3/2-way valve: 32)	32 (by use of Type 0461: 24)
Pneumatic intermediate supply module	necessary after 24 valve functions; with 2 x 3/2-way valve: necessary after 16 valve functions	necessary after 16 valve functions

to be continued on page 2

Specifications	Pilot valve type	
	0460, 6524, 6525 	0461, 6526, 6527 
Fieldbus type	DeviceNet, EtherNet/IP, PROFIBUS DP	DeviceNet, EtherNet/IP, PROFIBUS DP
Electrical modules	Rockwell Point I/O System	Rockwell Point I/O System
Digital modules	2 or 4 inputs 2 or 4 outputs, others on request	2 or 4 inputs 2 or 4 outputs, others on request
Analog modules	2 or 4 inputs (0-10 V, 0-20 mA, 4-20 mA, RTD, TC) 2 outputs (0-10 V, 0-20 mA, 4-20 mA) others on request	2 or 4 inputs (0-10 V, 0-20 mA, 4-20 mA, RTD, TC) 2 outputs (0-10 V, 0-20 mA, 4-20 mA) others on request
Operating voltage	24 V/DC	24 V/DC
Permissible voltage tolerance	+20%/-15% (by use of Type 0460: ±10%)	+20%/-15% (by use of Type 0461: ±10%)
Residual ripple	1 Vss	1 Vss
Rated power per valve	1 W (0.5 W nominal power after 120 ms)	2 W (1 W nominal power after 120 ms)
Rated current per valve	43 mA (28 mA holding current after 120 ms) 41 mA (by use of Type 0460)	85 mA (52 mA holding current after 120 ms) 41 mA (by use of Type 0461)
Temperatures	Operating: 0 to +55°C (by use of Type 0460: 0 to +50°C) Storage: -20 to +60°C	Operating: 0 to +55°C (by use of Type 0461: 0 to +50°C) Storage: -20 to +60°C
Rating	IP20 IP65 in closed field housing	IP20 IP65 in closed field housing
Approvals for hazardous areas	Zone 2	on request

Application example

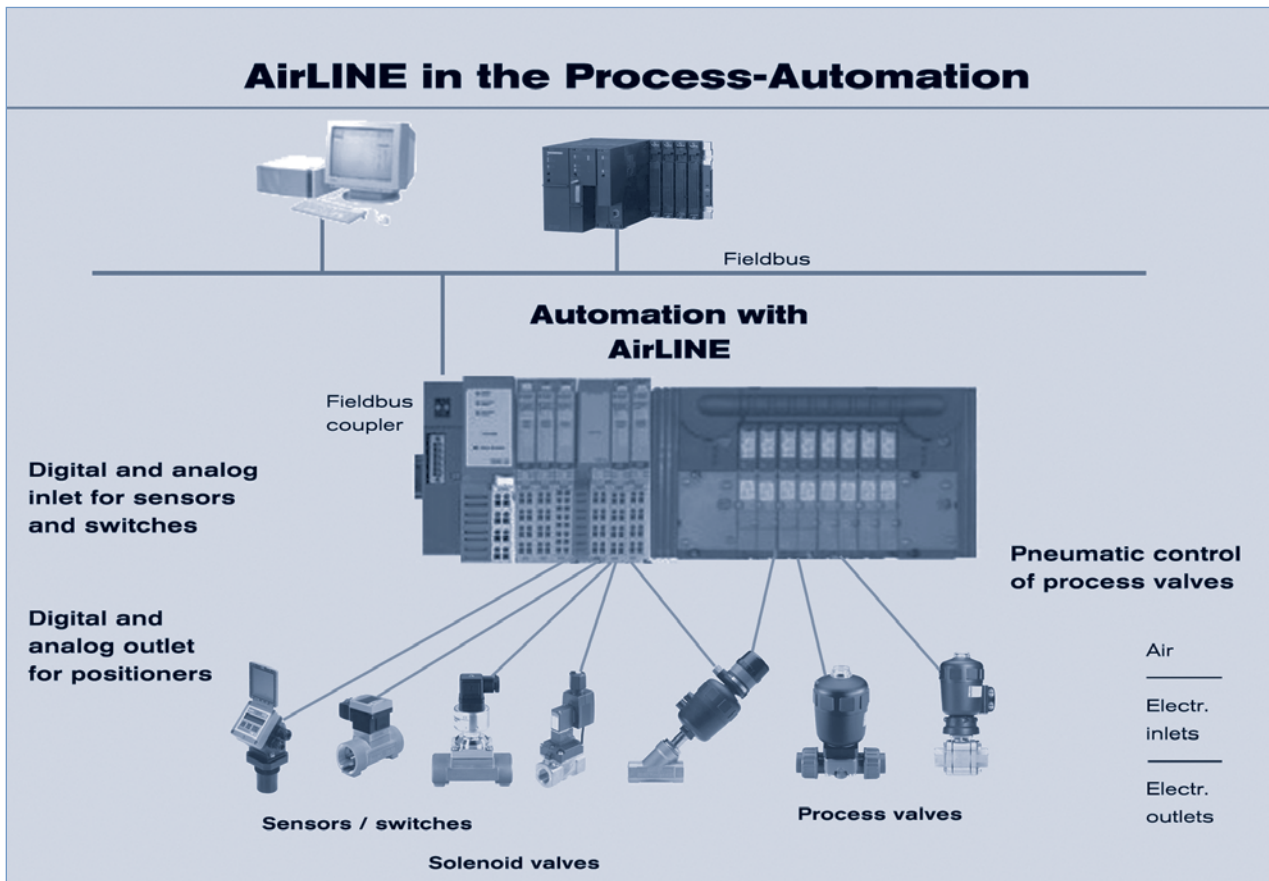

Configuration software

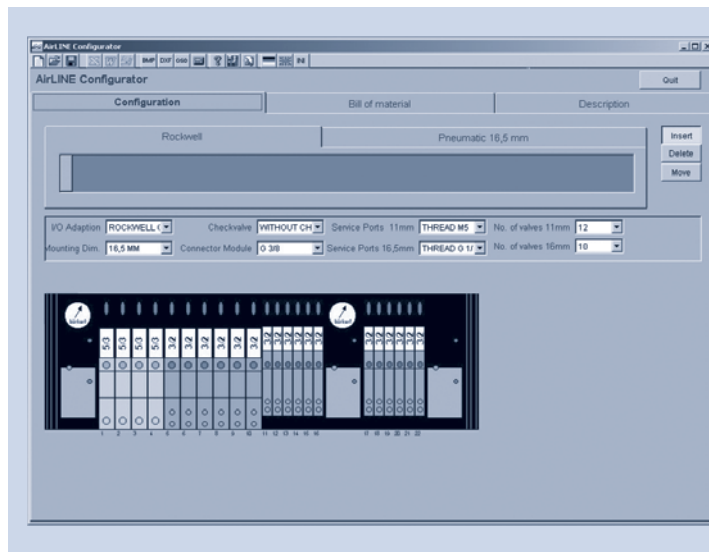

AirLine is a system of modular design which is precisely adapted to the specific requirements of the customer. Burkert offers a software program, the Configurator, for the simple, precise generation of the required configuration of each Airline system.

The Burkert Configurator defines:

- Number and types of valves
- Type of (intermediate) supplies

The results supplied by the Configurator:

- Bill of materials, incl. list prices
- Illustration

For more information consult individual datasheets, downloadable at www.burkert.com

Pneumatic module and electrical interfaces for modules series Rockwell Point I/O System

Connector modules ME02

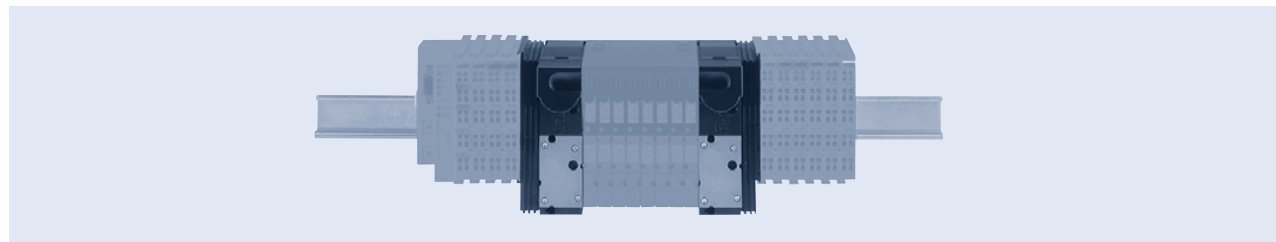

Connector module "left"

Description	Port connection	Item no.
Without pressure gauge	threaded port G 1/4	154 048
	threaded port NPT 1/4	154 050
	push-in 10 mm	154 049
With pressure gauge	threaded port G 1/4	154 054
	threaded port NPT 1/4	154 056
	push-in 10 mm	154 055

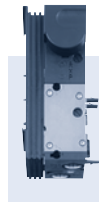

Connector module "right" and Pneumatic intermediate supply module

Description	Port connection	Item no.
Connector module "right"		
Without pressure gauge	threaded port G 1/4	154 051
	threaded port NPT 1/4	154 053
	push-in 10 mm	154 052
With pressure gauge	threaded port G 1/4	154 057
	threaded port NPT 1/4	154 059
	push-in 10 mm	154 058
Pneumatic intermediate supply module		
Without pressure gauge	threaded port G 1/4	154 077
	threaded port NPT 1/4	154 079
	push-in 10 mm	154 078
With pressure gauge	threaded port G 1/4	154 080
	threaded port NPT 1/4	154 082
	push-in 10 mm	154 081



DTS 1000012077 EN Version: G Status: RL (released | freigegeben | valide) printed: 30.06.2006

Pneumatic module and electrical interfaces for modules series Rockwell Point I/O System

AirLINE valve modules

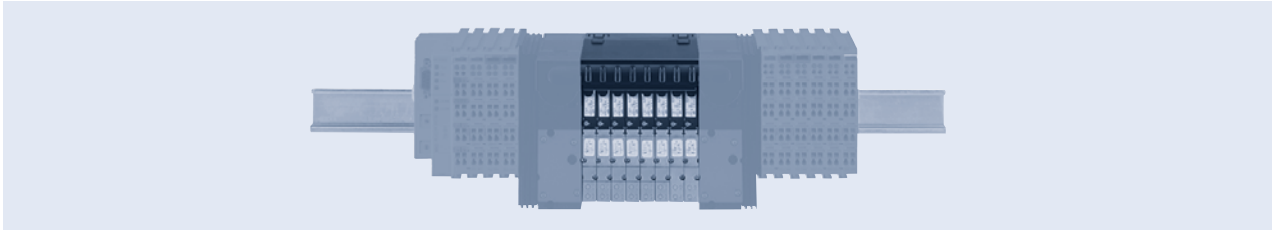

Pneumatic basic module, electrical basic module and pilot valves

2 valves wide/2 valves wide with 2 x 3/2-way valve

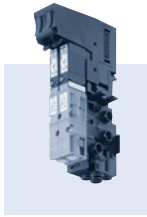

Service port 2 (A), 4 (B)

- Threaded port M5
- Threaded port M7
- Push-in ø 6 mm
- Push-in ø 1/4"
- Push-in ø 5/32"

8 valves wide/8 valves wide with 2 x 3/2-way valve

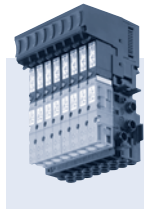

Service port 2 (A), 4 (B)

- Threaded port M5
- Threaded port M7
- Push-in ø 6 mm
- Push-in ø 1/4"
- Push-in ø 5/32"

Further pneumatic accessories

Typ 0498

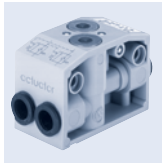

Double pilot controlled
check Valve

Available options on request

- Check valves in R, S and P-shut
- Covering plate for spare channels
- Channel separation plugs to build different pressure areas

11mm width per station: Multi-way solenoid valve Types 6524 and 6525

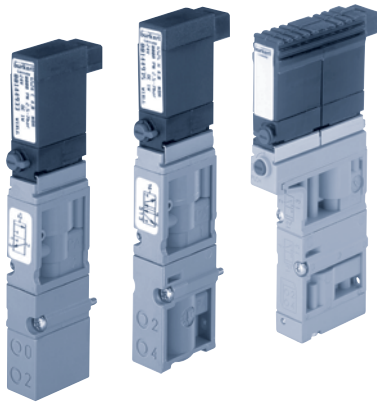

The solenoid valve Types 6524 and 6525 consist of a pneumatic valve body fitted with Type 6104 rocker pilot valve. The rocker principle allows switching of high pressure at low power consumption and fast response times. The pilot valves are equipped with manual override as a standard.

The 2 x 3/2-way valve version is the combination of two pilot rocker solenoid valves type 6104 and a pneumatic seat valve.

Specification	3/2-way valve	2 x 3/2-way valve
Body material	PA (polyamide)	
Seal material	FPM, NBR	
Media	Lubricated and non-lubricated dry air, neutral gases (5 µm-Filter)	
Port connection	Flange for MP11	
Manual override	As a standard feature	
Voltage	24 V DC	
Nominal power	1 W	2 x 1 W with reduction of power consumption
Duty cycle	Continuous operation (100% ED)	
Elec. connection on valve	Rectangular plug 2-pole with raster 5.08 mm	Rectangular plug 3-pole with raster 2.54 mm
Mounting	With 2 screws M2 x 20	With 2 screws M2 x 28
Installation position	As required, preferably with pilot valve upright	
Flow rate: QNn value air [l/min]	Measured at +20°C, 6 bar pressure at valve inlet and 1 bar pressure difference	
Pressure ranges [bar]	Measured as overpressure to the atmospheric pressure	
Response times [ms]	Measured according to ISO 12238	

Order chart for valves

Circuit function	Orifice [mm]	QNn value air [l/min]	Pressure range [bar]	Response times		Voltage/Frequency [V/Hz]	Item no.
				Opening [ms]	Closing [ms]		
Circuit function C 3/2-way valve, servo-assisted in de-energized position port 2 to atmosphere	4	300	Vac.-7	15	20	24 V DC	153 958
			1-7 ¹⁾	15	20	24 V DC	150 333
			2.5-7	12	20	24 V DC	144 933
			2.5-10	15	28	24 V DC	148 227
Circuit function D 3/2-way valve, servo-assisted in de-energized position port 2 pressurized	4	300	1.0-7 ¹⁾	12	20	24 V DC	150 334
			2.5-7	12	20	24 V DC	144 934
			2.5-10	15	28	24 V DC	152 139
Circuit function H 5/2-way valve, servo-assisted in de-energized position port 1 connected to port 2, port 4 exhausted	4	300	1.0-7 ¹⁾	15	20	24 V DC	150 335
			2.5-7	15	20	24 V DC	144 935
			2.5-10	20	28	24 V DC	150 610
Circuit function C 2 x 3/2-way valve, servo-assisted in de-energized position port 2/4 to atmosphere	4	300	1.0-7 ¹⁾	12	20	24 V DC	170 269 ²⁾
			2.5-7	12	20	24 V DC	170 268 ²⁾

¹⁾ Version with auxiliary air.

²⁾ Version with integrated reduction of power consumption

11 mm width per station: Multi-way solenoid valve Types 0460



The solenoid valve Type 0460 consists of a pneumatic valve body fitted with a double coil pilot valve. The principle allows switching of high pressures together with low power consumption and fast response times. All valves are equipped with manual override as a standard.

Technical data	
Body material	Aluminium
Seal material	NBR
Media	Lubricated and non-lubricated dry air, neutral gases (5 µm-filter recommended)
Port connection	Flange
Pneumatic module	MP11
Supply port 1 (P), 3 (R), 5 (S)	G 1/4 NPT 1/4 Push-in connection Ø 10 mm
Service port 2 (A), 4 (B)	Push-in connection Ø 6 mm Push-in connection Ø 1/4" Push-in connection Ø 4 mm = ø 5/32" M5 M7
Voltage	24 V DC
Electrical connection on valve	Rectangular plug
Manual override	Standard
Flow rate: Q _{Nn} -value air [l/min]	Measured at +20°C, 6 bar pressure at valve inlet and 1 bar pressure difference
Pressure ranges [bar]	Measured as overpressure to the atmospheric pressure
Response times [ms]	Measured according to ISO 12238

Ordering chart valves

Circuit function	Orifice [mm]	Q _{Nn} -value air [l/min]	Pressure range [bar]	Nominal power [W]	Response times		Item no.
					Opening [ms]	Closing [ms]	
<p>H</p> <p>5/2-way valve, servo-assisted impulse version</p>	2.5	200	2.0-7.0	1	15	15	154 183
<p>L</p> <p>5/3-way valve, servo-assisted in middle position all ports blocked</p>	2.5	200	2.0-7.0	1	15	20	154 184
<p>N</p> <p>5/3-way valve, servo-assisted in middle position port 2 and 4 exhausted</p>	2.5	200	2.0-7.0	1	15	20	154 185

Dimensions [mm]

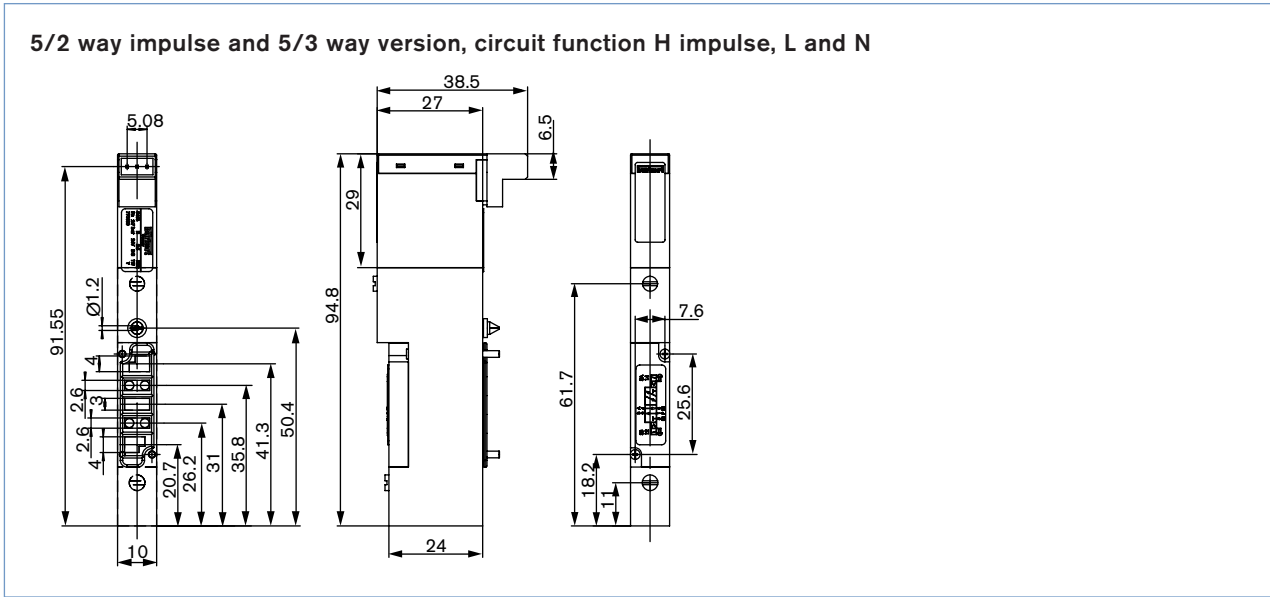

16.5mm width per station: Multi-way for solenoid valve Types 6526 and 6527



Specification	
Body material	PA (polyamide)
Seal material	NBR
Media	Lubricated and non-lubricated dry air, neutral gases (10 µm filter)
Port connection	Flange for MP12
Manual override	Standard
Voltage	24 V DC
Nominal power	2 W, 1W
Duty cycle	Continuous operation (100% ED)
Elec. Connection on valve	Tag connector acc. to DIN EN 175301-803 (previously DIN 43650) Form C
Mounting	With 2 screws M3x30
Installation position	As required, preferably with pilot valve upright

Flow rate: QNn value air [l/min]	Measured at +20°C, 6 bar pressure at valve inlet and 1 bar pressure difference
Pressure ranges [bar]	Measured as overpressure to the atmospheric pressure
Response times [ms]	Measured acc. to ISO 12238

The solenoid valve Types 6526 and 6527 consist of a pneumatic valve body fitted with Type 6106 rocker pilot valve. The rocker principle allows switching of high pressure at low power consumption and fast response times. The pilot valves are equipped with manual override as a standard.

Order chart for valves

Circuit functions	Orifice [mm]	QNn value air [l/min]	Pressure range [bar]	Nominal power [W]	Response times		Voltage/Fre-quency [V/Hz]	Item no.
					Opening [ms]	Closing [ms] ³⁾		
C 3/2-way valve, servo-assisted in de-energized position port 2 to atmosphere	6	700	1.0 - 10 ¹⁾	2	20	12	24 V DC	156 842
			1.0 - 10 ¹⁾	2	20	12	24 V DC	163 028 ²⁾
			2.0 - 10	2	20	12	24 V DC	156 318
			2.0 - 10	2	20	12	24 V DC	158 944 ²⁾
			2.0 - 8.0	1	20	17	24 V DC	156 840
			2.0 - 8.0	1	20	12	24 V DC	158 947 ²⁾
D 3/2-way valve, servo-assisted in de-energized position port 2 pressurized	6	700	1.0 - 10 ¹⁾	2	12	20	24 V DC	157 672
			1.0 - 10 ¹⁾	2	20	12	24 V DC	163 029 ²⁾
			2.0 - 10	2	12	20	24 V DC	156 320
			2.0 - 10	2	20	12	24 V DC	158 946 ²⁾
			2.0 - 8.0	1	17	20	24 V DC	156 841
			2.0 - 8.0	1	20	12	24 V DC	158 948 ²⁾
H 5/2-way valve, servo-assisted in de-energized position port 1 connected to port 2, port 4 exhausted	6	700	1.0 - 10 ¹⁾	2	20	12	24 V DC	156 828
			1.0 - 10 ¹⁾	2	20	12	24 V DC	163 030 ²⁾
			2.0 - 10	2	20	12	24 V DC	156 337
			2.0 - 10	2	20	12	24 V DC	158 942 ²⁾
			2.0 - 8.0	1	20	17	24 V DC	156 827
			2.0 - 8.0	1	20	12	24 V DC	158 943 ²⁾

¹⁾ version with auxiliary air

²⁾ electric connection with manual override.

³⁾ closing time approx. 5 ms higher when used together with valve unit

16.5 mm width per station: Multi-way solenoid valve Type 0461

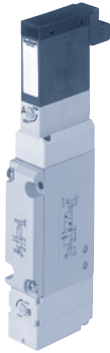

The solenoid valve Type 0461 consists of a pneumatic valve body fitted with a double coil pilot valve. The principle allows switching of high pressures together with low power consumption and fast response times. All valves are equipped with manual override as a standard.

Technical data	
Body material	Aluminium
Seal material	NBR
Media	Lubricated and non-lubricated dry air, neutral gases (10 µm-filter recommended)
Port connection	Flange
Pneumatic module	MP12
Supply port 1 (P), 3 (R), 5 (S)	G 3/8 NPT 3/8
Service port 2 (A), 4 (B)	G 1/8 NPT 1/8 Push-in connection Ø 8 mm
Operating voltage	24 V DC
Electrical connection on valve	Rectangular plug
Manual override	Standard
Flow rate: Q _{Nn} -value air l/min]	Measured at +20°C, 6 bar pressure at valve inlet and 1 bar pressure difference
Pressure ranges [bar]	Measured as overpressure to the atmospheric pressure
Response times [ms]	Measured according to ISO 12238

Ordering chart valves

Circuit function	Orifice [mm]	Q _{Nn} -value air [l/min]	Pressure range [bar]	Nominal power [W]	Response times		Item no.
					Opening [ms]	Closing [ms]	
<p>H</p> <p>5/2-way valve, servo-assisted impulse version</p>	6	500	2.5-7.0	1	20	30	156 766
<p>L</p> <p>5/3-way valve, servo-assisted in middle position all ports blocked</p>	6	500	2.5-7.0	1	15	50	156 767
<p>N</p> <p>5/3-way valve, servo-assisted in middle position port 2 and 4 exhausted</p>	6	500	2.5-7.0	1	15	50	156 768

Dimensions [mm]

5/2 way impulse and 5/3 way version, circuit function H impulse, L and N

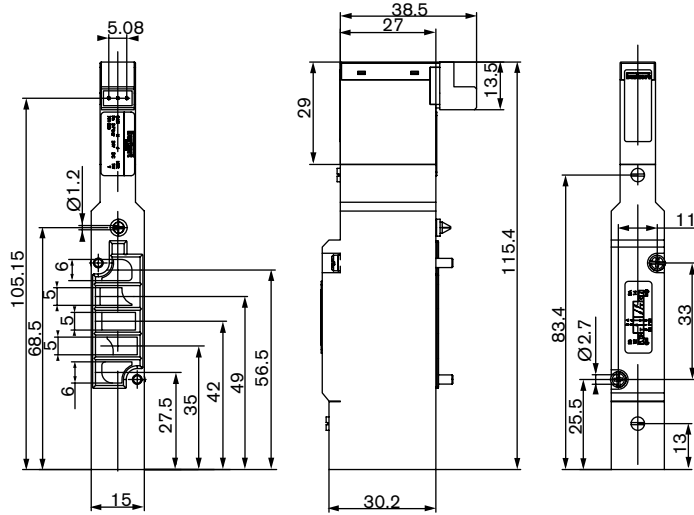

Pneumatic modules and electrical interfaces for modules series Rockwell Point I/O System

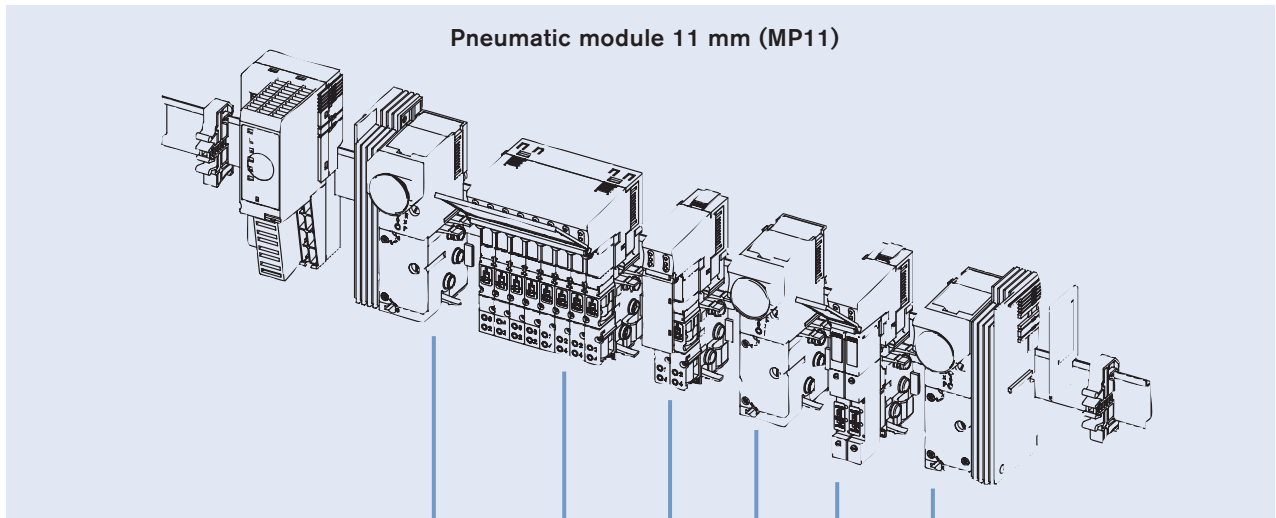

**Connector module "left",
with or without pressure gauge**

Threaded port G 1/4
Threaded port NPT 1/4
Push-in 10 mm

**Pneumatic basic module, electrical
basic module and pilot valves**

8 valves wide (4 x 11 mm)

Service port 2 (A), 4 (B)

Threaded port M5
Threaded port M7
Push-in \varnothing 4 mm and 5/32"
Push-in \varnothing 6 mm
Push-in \varnothing 1/4"

2 valves wide (2 x 11 mm)

Service port 2 (A), 4 (B)

Threaded port M5
Threaded port M7
Push-in \varnothing 4 mm and 5/32"
Push-in \varnothing 6 mm
Push-in \varnothing 1/4"

**Connector module "right",
With or without pressure gauge**

Threaded port G 1/4
Threaded port NPT 1/4
Push-in 10 mm

**Pneumatic basic module, electrical
basic module and pilot valves**

2 valves wide (2 x 11 mm)

Service port 2 (A), 4 (B)
Threaded port M5
Threaded port M7
Push-in \varnothing 4 mm and 5/32"
Push-in \varnothing 6 mm
Push-in \varnothing 1/4"

**Intermediate supply module, with or
without pressure gauge**

Threaded port G 1/4
Threaded port NPT 1/4
Push-in 10 mm

Pneumatic modules and electrical interfaces for modules series Rockwell Point I/O System

Pneumatic module 16.5 mm (MP12)

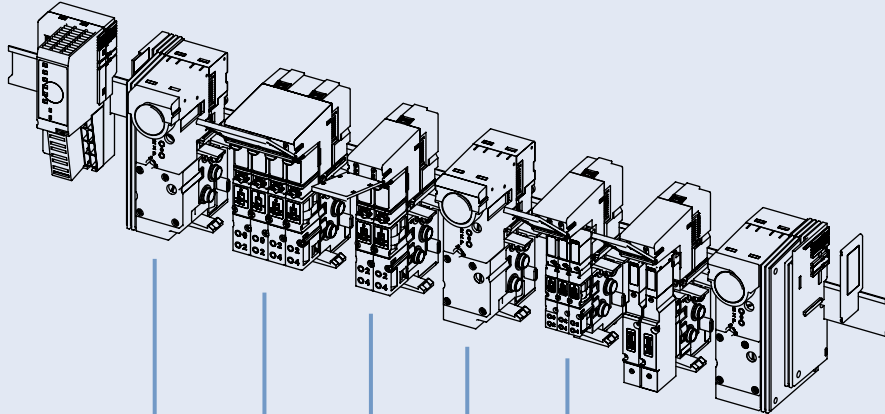

**Connector module "left",
With or without pressure gauge**

Threaded port G 3/8
Threaded port NPT 3/8

**Pneumatic basic module, electrical
basic module and pilot valves**

4 valves wide (4 x 16.5 mm)

Service port 2 (A), 4 (B)

Threaded port G1/8
Threaded port NPT1/8
Push-in ø 8 mm and ø 5/16"

2 valves wide (2 x 16.5 mm)

Service port 2 (A), 4 (B)

Threaded port G1/8
Threaded port NPT1/8
Push-in ø 8 mm and ø 5/16"

**Connector module "right",
With or without pressure gauge**

Threaded port G 3/8
Threaded port NPT 3/8

**Pneumatic basic module, electrical
Basic module and pilot valves**

3 valves wide (3 x 11 mm)

Service port 2 (A), 4 (B)

Threaded port M5
Threaded port M7
Push-in ø 6 mm

**Intermediate supply module,
With or without pressure gauge**

Threaded port G 3/8
Threaded port NPT 3/8

Dimensions [mm]

11 mm mounting dimensions for Type 6524 / 6525

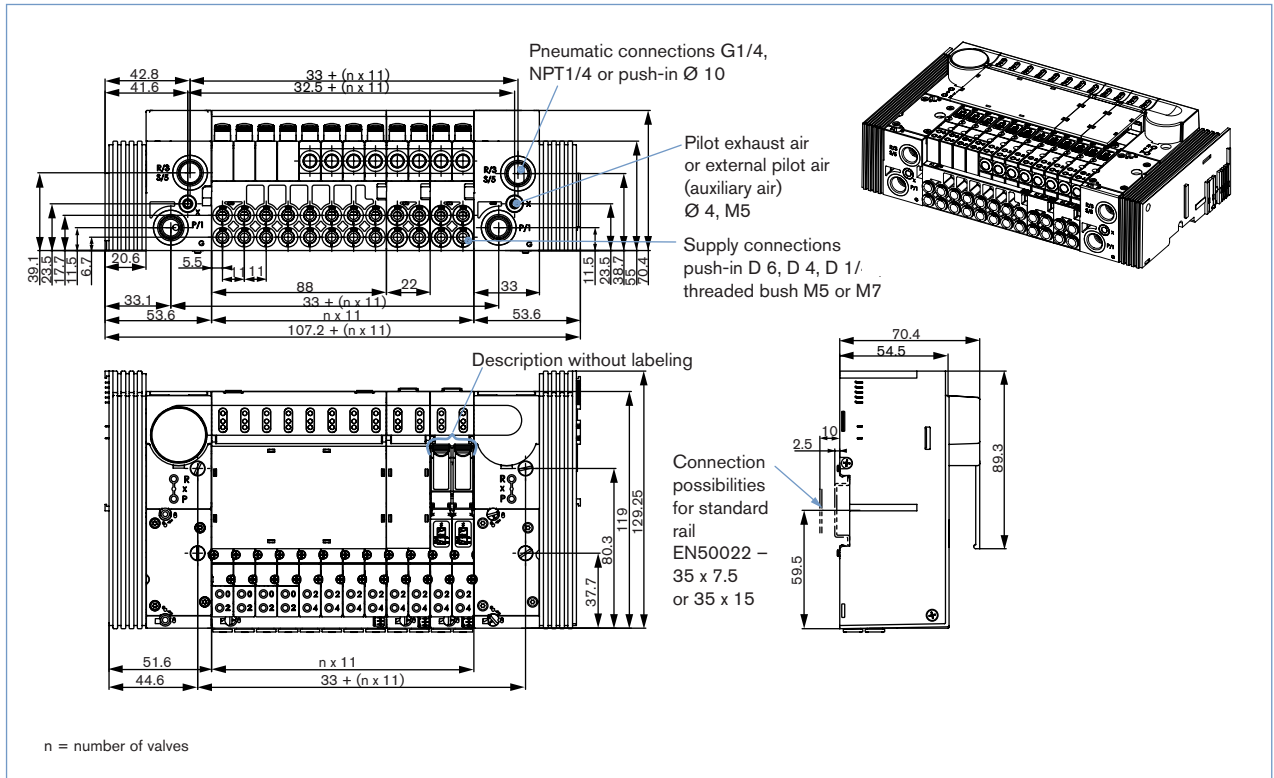

11 mm mounting dimensions for Type 6524 2 x 3/2-way valve

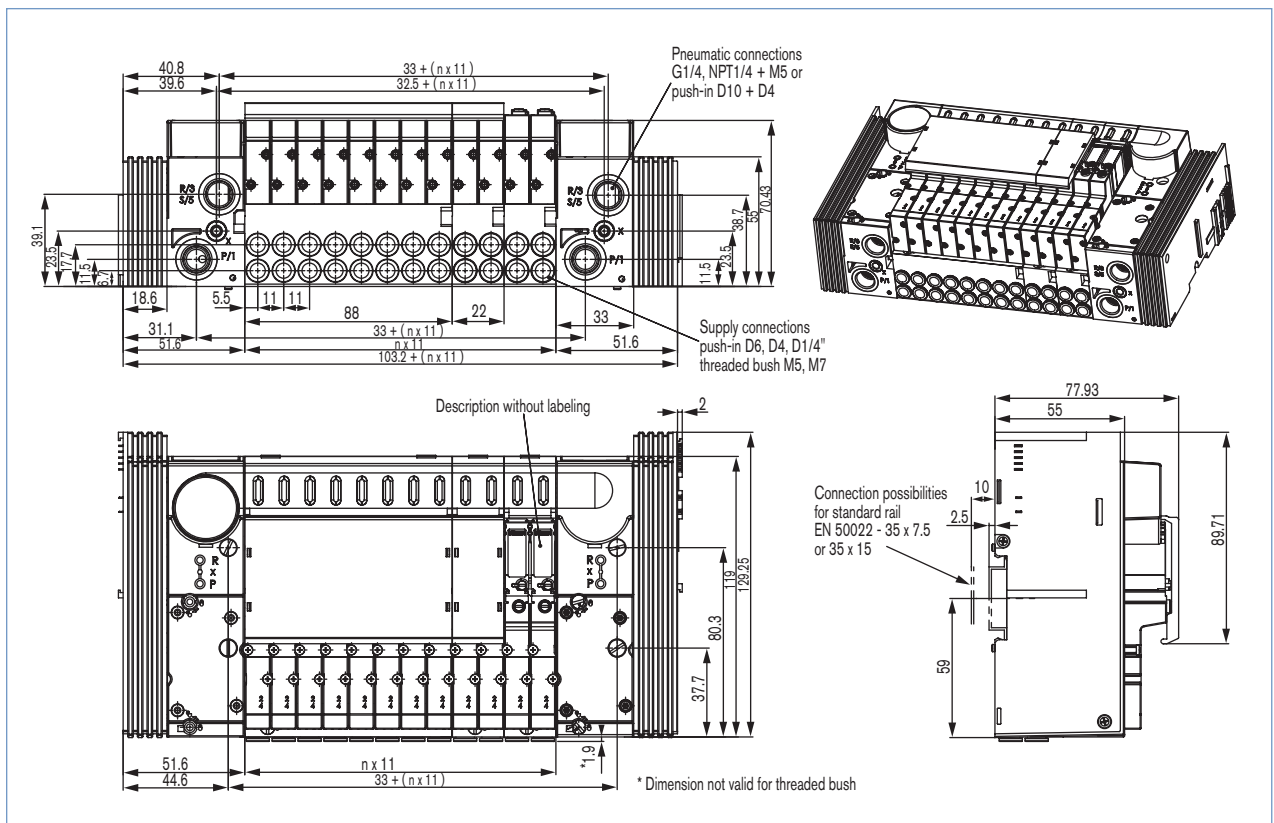

Dimensions [mm]

16.5 mm mounting dimensions for Type 6526 / 6527

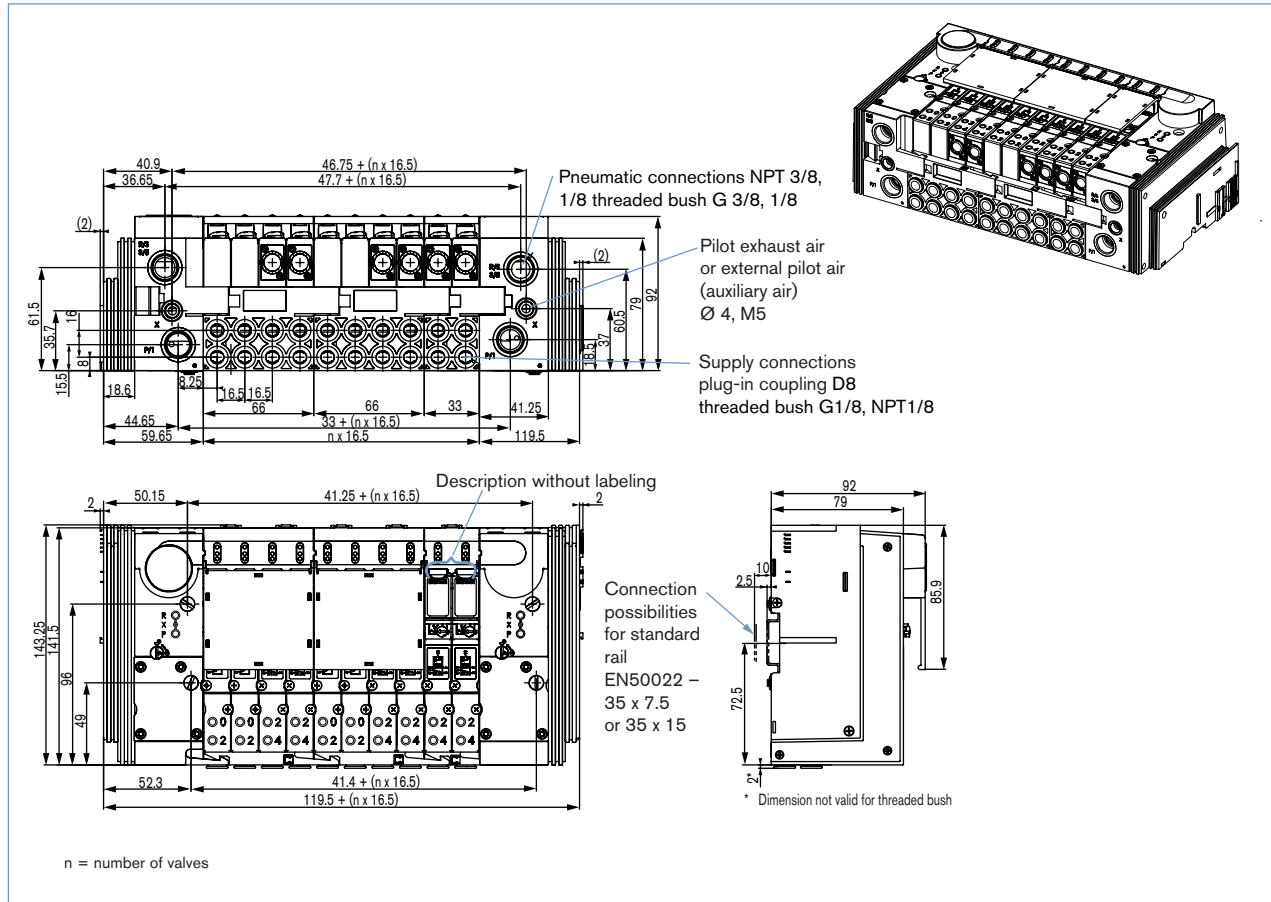

DTS 1000012077 EN Version: G Status: RL (released | freigegeben | validé) printed: 30.06.2006

To find your nearest Bürkert facility, click on the orange box →

www.burkert.com

In case of special application conditions, please consult for advice. We reserve the right to make technical changes without notice. 0604/4_EU-en_00891879