

2/2 way Angle-Seat Control Valve with stainless steel design for medium up to +185 °C, DN15-50



- Excellent combination of good control characteristic and high flow rates
- High cycle life
- Clean design for optimal use in hygienic environment

Type 2300 clamp can be combined with...



Type 8692/8693
Positioner / Process Controller TopControl



Type 8694
Positioner TopControl Basic



Type 8696
Positioner TopControl Basic



Type 8792/93
SideControl Remote version

In line with Bürkert's philosophy for modular valves and sensors the construction of the 2300 angle-seat valve fulfils tough criteria for process environments. Unrivalled cycle life and sealing integrity is guaranteed by the proven self adjusting spindle packing with V-seals.

The parabolic trim results in a flow characteristic approximately 35% larger than conventional control valves. It is available in either stainless steel on stainless steel or with a durable PTFE seal for tight shut-off.

The design enables the easy integration of automation modules whether they are digital electropneumatic positioner or process controller.

The fully integrated system has a compact and smooth design, integrated pneumatic lines, IP65/67 protection class and superior chemical resistance.

This system has been engineered for reliable accurate control in applications where high flow rate is an advantage.

Technical data	
Orifice	DN15 to 50
Port connections Clamp acc. to Threaded port and welded - see separate datasheets	ISO 2852, ASME BPE (DIN 32676, BS4825 on request)
Body material	Stainless steel 316L
Nominal pressure	PN25 (Body)
Actuator material Actuator Cover	PPS Stainless steel 1.4561 (316Ti)
Plug sealing	PTFE/St.st. (PTFE/stainless steel) and St.st./St.st. (stainless steel/stainless steel)
Seat leakage IEC 534-4/EN 1349	Shut-off class III and IV for St.st./St.st. Shut-off class VI for PTFE/St.st.
Medium	Water, alcohol, oils, fuels, hydraulic fluids, salt solution, alkali solutions, organic solvents, steam, optional fuel gas (EC Gas Appliances Directive 2009/142/EG)
Viscosity	max. 600 mm ² /s
Spindle packing	PTFE V-seals with spring compensation
Medium temperature	- 10 to + 185 °C (max. + 130 °C for PTFE/St.st. sealing)
Ambient temperature	0 to + 55 °C (when used with positioner or process controllers) 0 to + 80 °C (remote version)
Control medium	Compressed air
Relevant pilot pressure for circuit function A	5.5 to 7 bar
Pilot air ports	Push-in connector for external Ø 6 mm or ¼" tube
Installation	As required, preferably with actuator in upright position
Surface Finish, standard on request	in internal connection area ¹⁾ Ra ≤ 0.6 (electro polished) outer cast surface

¹⁾ In the seat area the Ra ≤ 0.6 µm surface finish can be higher.

Content



Valve specifications

Type 2300 clamp

Technical data & ordering info.

p. 1 - 4



System Continuous ELEMENT

Type 8802-YG

Ordering info. & technical data

p. 5 - 9

Request for quotation

Type 8802-YG

p. 10

Technical data Type 2300, continued

 K_{vs} values water/pressure

Orifice [mm]	Actuator size [mm]	K_{vs} value water [m ³ /h]	Minimum pilot pressure [bar] *	Operating pressure up to +185 °C NC [bar] *
15	50 / 70	5	5.5	16
20	50 / 70	10	5.5	10 / 16
25	50 / 70 / 90	16	5.5	5 / 12 / 16
32	70 / 90	23	5.5	6 / 16
40	90	34	5.5	12
	130	36	5.5	16
50	90	49	5.5	7
	130	53	5.5	16

* For NO (normally open) see charts on page 4

Flow rate: K_{vs} value water [m³/h]: Measured at +20 °C, 1 bar pressure at valve inlet and free outlet.

Pressure valves [bar]: Overpressure to the atmospheric pressure

Flow characteristic

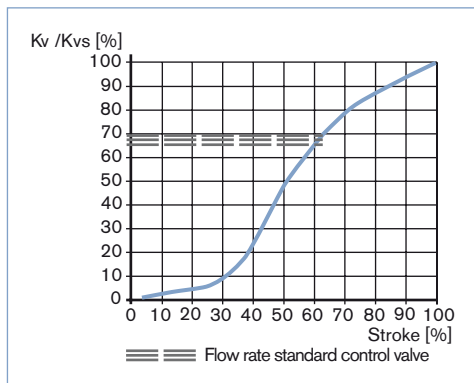

Remarks on the flow characteristic

Modified equi-percentile flow characteristic, engineered for a quick response during peak flow demand (an advantage for many processes like heating/cooling with heat exchangers) and fine control at lower flow.

 K_{vs} values [m³/h]

Orifice [mm]	Actuator size [mm]	Stroke [%]										
		5	10	20	30	40	50	60	70	80	90	100
15	50 / 70	0.16	0.17	0.22	0.4	1.2	2.7	3.5	4.0	4.5	4.8	5
20	50 / 70	0.26	0.27	0.4	1.1	4.0	5.9	7.2	8.3	9.1	9.6	10
25	50 / 70 / 90	0.34	0.36	0.62	1.5	5.2	8.9	11.5	13.0	14.2	15.4	16
32	70 / 90	0.43	0.52	0.82	1.4	4.0	9.3	13.8	16.4	19.2	21.3	23
40	90	0.47	0.62	1.1	2.6	10.0	17.0	21.5	25.3	28.8	31.6	34
	130	0.48	0.66	1.4	5.1	14.0	20.0	24.3	28.3	31.7	34.5	36
50	90	0.85	1.1	1.6	2.7	10.2	20.0	28.6	35.6	40.6	45.0	49
	130	0.87	1.2	1.8	4.0	15.2	26.0	35.0	40.3	45.0	48.0	53

Ordering chart Type 2300, flow direction below the seat (for gases and liquids)

Clamp acc. to ISO 2852

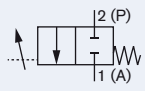
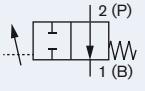
Control function	Orifice [mm]	Actuator size Ø [mm]	Port connection clamp external Ø [mm]	K _{vs} value water [m³/h]	Operating pressure up to +185 °C [bar]	Article no. plug sealing PTFE/St. st.	Leakage class	Article no. plug sealing St. st./St. st.	Leakage class
A Pneumatically operated control valve, normally closed by spring force, flow direction below seat 	15	50	34.0	5	16	203649	VI	223423	IV
		70	34.0	5	16	203650	VI	223424	IV
	20	50	50.5	10	10	203651	VI	223425	III
		70	50.5	10	16	203652	VI	223426	IV
	25	50	50.5	16	5	203653	VI	223427	III
		70	50.5	16	12	203654	VI	223428	III
		90	50.5	16	16	245401	VI	245414	IV
	32	70	50.5	23	6	203655	VI	223429	III
		90	50.5	23	16	204768	VI	245415	IV
	40	90	64.0	34	12	203656	VI	223430	III
		130	64.0	36	16	223304	VI	223431	IV
	50	90	77.5	49	7	203657	VI	223433	III
		130	77.5	53	16	213706	VI	223434	IV
	B Pneumatically operated control valve, normally open by spring force, flow direction below seat 	15	50	34.0	5	see charts on page 4	203658	VI	223435
70			34.0	5	203659		VI	223436	IV
20		50	50.5	10	203660		VI	223437	III
		70	50.5	10	203661		VI	223438	IV
25		50	50.5	16	203662		VI	223439	III
		70	50.5	16	203663		VI	223440	III
32		70	50.5	23	203664		VI	223441	III
40		90	64.0	34	203665		VI	223442	IV
50		90	77.5	49	203666		VI	223443	III

Clamp acc. to ASME BPE

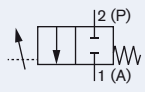
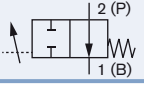
Control function	Orifice [mm]	Actuator size Ø [mm]	Port connection clamp external Ø [mm]	K _{vs} value water [m³/h]	Operating pressure up to +185 °C [bar]	Article no. plug sealing PTFE/St. st.	Leakage class	Article no. plug sealing St. st./St. st.	Leakage class
A Pneumatically operated control valve, normally closed by spring force, flow direction below seat 	15	50	25.0	5	16	203667	VI	223444	IV
		70	25.0	5	16	203668	VI	223445	IV
	20	50	25.0	10	10	203669	VI	223446	III
		70	25.0	10	16	203670	VI	223447	IV
	25	50	50.5	16	5	203671	VI	223448	III
		70	50.5	16	12	203672	VI	223449	III
		90	50.5	16	16	245402	VI	245416	IV
	40	90	50.5	34	12	203673	VI	223450	III
		130	50.5	36	16	223305	VI	223451	IV
	50	90	64.0	49	7	203674	VI	223452	III
130		64.0	53	16	213707	VI	223453	IV	
B Pneumatically operated control valve, normally open by spring force, flow direction below seat 	15	50	25.0	5	see charts on page 4	203675	VI	223454	III
		70	25.0	5		203677	VI	223455	IV
	20	50	25.0	10		203678	VI	223456	III
		70	25.0	10		203679	VI	223457	IV
	25	50	50.5	16		203680	VI	223458	III
		70	50.5	16		203681	VI	223459	III
	40	90	50.5	34		203682	VI	223460	IV
	50	90	64.0	49		203683	VI	223461	III

 Further versions on request

Port connection

Clamp acc. to DIN 32676, BS4825



Control function

B (spring-return normally-open) and I (double-acting)

Materials Type 2300

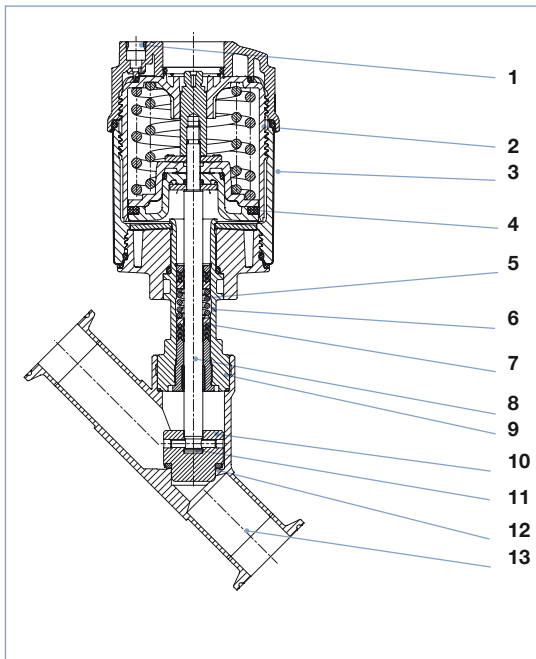

- | | | |
|----|----------------------------|--|
| 1 | Pilot air ports | Push-in connector PP (standard) |
| 2 | Actuator | PPS |
| 3 | Cover | Stainless steel 1.4561 (316Ti) |
| 4 | Piston seal | FKM |
| 5 | Spring | Stainless steel 1.4310 |
| 6 | Tube | Stainless steel 1.4401 (316) / 1.4404 (316L) |
| 7 | Spindle packing | PTFE |
| 8 | Spindle | Stainless steel 1.4401 (316) / 1.4404 (316L) |
| 9 | Spindle guidance | Stainless steel 1.4404 (316L) |
| 10 | Plug | Stainless steel 1.4571 |
| 11 | Spring straight pin | Stainless steel 1.4310 |
| 12 | Plug seal | Stainless steel 1.4571 / PTFE disc for soft seat sealing |
| 13 | Valve body | Stainless steel 316L |

Pressure Charts with control function B (normally open, NO)

Ø 50

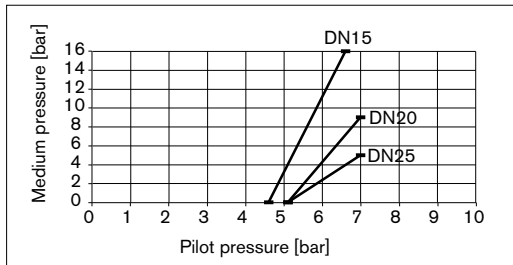

Ø 70

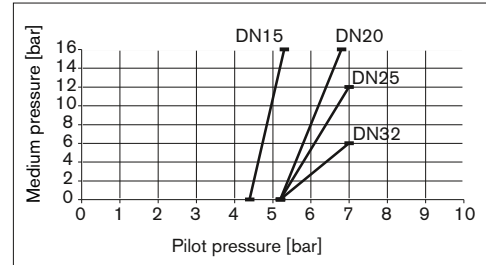

Ø 90

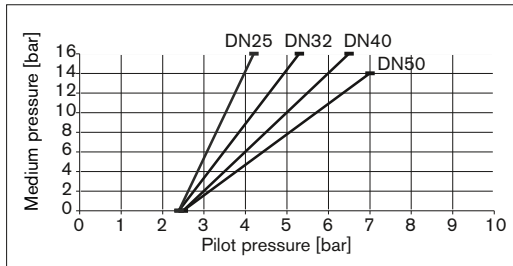

Ø 130

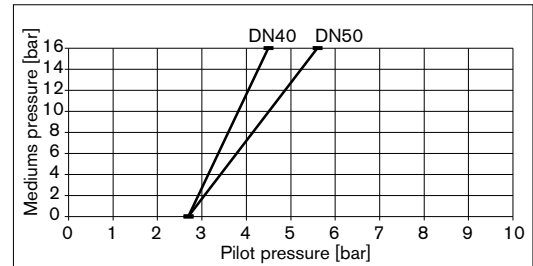

Ordering information for valve system Continuous ELEMENT Type 8802-YG

A valve system Continuous ELEMENT Type 8802-YG consists of an angle-seat control valve Type 2300 and a digital electropneumatic Positioner Type 8692, a digital electropneumatic Process Controller Type 8693, a digital electropneumatic Positioner Basic Type 8694 (below), an electropneumatic Positioner Type 8792/8793 (for valve actuator sizes Ø 70/90/130 mm) or a digital electropneumatic Positioner Type 8696 (for valve actuator size Ø 50 mm) (see next page and separate datasheets). For the configuration of further valve systems please use the "Request for quotation". You order two components and receive a complete assembled and certified valve.

Ordering the valve system Continuous ELEMENT Type 8802-YG

Angle seat valve Type 2300



Positioner



Positioner
Type 8692



Process Controller
Type 8693



Positioner Basic
Type 8694

**Angle seat valve
with desired control unit**



Valve system
Continuous
ELEMENT
Type 8802-YG-I
2300 + 8692



Valve system
Continuous
ELEMENT
Type 8802-YG-J
2300 + 8693



Valve system
Continuous
ELEMENT
Type 8802-YG-L
2300 + 8694

When you click on the orange box "More info." below, you will come to our website for the resp. product where you can download the

**Positioner TopControl
Type 8692**

More
info.

**Process Controller
TopControl Type 8693**

More
info.



PROFIBUS
DeviceNet™

The new generation of integrated positioners/process controllers for combination with actuators from the process valve series Type 23xx/2103 is specially designed for the requirements of hygienic process environments. The easy handling and the selection of additional software functions are done either on a big graphic display with backlight and keypad or via a PC interface. A contact-free analogue position sensor registers the valve position without deterioration. Single-acting or double-acting actuators are controlled via the integral positioner system. With Type 8693, the process controller function is superimposed on the position control loop. Profibus DPV1 and DeviceNet communication interfaces are available as options.

Main customer benefits:

- Compact design of the valve system with integrated positioner/process controller meets the demands for plant washdown environments through the selection of materials, external seals and integrated control air supply to the actuator
- Extremely simple commissioning and operation thanks to the backlighting of the graphics display and proven multilingual software structure
- Automatic parameterisation of the positioner and process controller using the TUNE functions
- Field bus communication via Profibus DPV1 or DeviceNet
- Air intake filter enhances the process valve system availability
- Simple and reliable actuator adaption

Positioner TopControl Basic Type 8694

More
info.



The new generation of integrated positioners for combination with actuators from the process valve series Type 23xx/2103 is specially designed for the requirements of hygienic process environments. The operation and selection of the software functions close tight function, inversion of the operating direction of the setpoint signal, characteristic curves selection and switching manual/automatic operation are effected via push-buttons and DIP switches or via the PC interface. The position setpoint is set using the standard signal 4-20 mA. In addition, the enable can be controlled via the binary input and an optional position feedback can be integrated.

The positioner, Type 8694, registers the valve position without deterioration through a contact-free analogue position sensor. Single-acting or double-acting actuators are controlled via the integral positioner system. An AS-Interface communication interface is available as an option.

Main customer benefits:

- Compact design of the valve system with integrated positioner meets the demands for plant washdown environments through the selection of materials, external seals and integrated control air supply to the actuator
- Automatic parameterisation of the positioner using the Process TUNE function
- Field bus communication via optional AS-Interface
- Air intake filter enhances the process valve system availability
- Simple and reliable actuator adaption allowing additional actuators of the process valve series, Type 20xx or actuators from other manufacturers to be used

Ordering information for valve system Continuous ELEMENT Type 8802-YG, continued

A valve system Continuous ELEMENT Type 8802-YG consists of an angle-seat control valve Type 2300 and a digital electropneumatic Positioner Type 8692, a digital electropneumatic Process Controller Type 8693, a digital electropneumatic Positioner Basic Type 8694 (previous page), an electropneumatic Positioner Type 8792/8793 (for valve actuator sizes Ø 70/90/130) mm or a digital electropneumatic Positioner Type 8696 (for valve actuator size Ø 50 mm) (see separate datasheets). For the configuration of further valve systems please use the "Request for quotation". You order two components and receive a complete assembled and certified valve.

Ordering the valve system Continuous ELEMENT Type 8802-YG

Angle seat valve Type 2300



Positioner



Positioner
Type 8792/
Process Controller Type 8793



TopControl Basic Type 8696
Only for actuator size
Ø 50 mm

**Angle seat valve
with desired control unit**



Valve system
Continuous ELEMENT
Type 8802-YG-P
2300 + 8792 /
Type 8802-YG-Q
2300 + 8793



Valve system
Continuous ELEMENT
Type 8802-YG-N
2300 + 8696

When you click on the orange box "More info." below, you will come to our website for the resp. product where you can download the datasheet.

Positioner SideControl Type 8792

More info.

Process Controller SideControl Type 8793

More info.



Type 8792/8793 is a digital electro-pneumatic positioner with an optional, integrated process controller (8793) for precise control requirements. The compact design with integrated position encoder and LCD display was developed for demanding applications of the process industry. A Profibus DPV1 communication interface is available as an option. Main customer benefits are:

- Time saving algorithms for temperature, flow and pressure PID parameters through ProcessTUNE function.
- Quick and simple menu driven parameterization through keyboard or Profibus DPV1 PA
- Adaption acc. to IEC534-6 and VDI/VDE 3845 for lift and swivel drives or as a Remote version together with Bürkert process valves
- Rugged anodised aluminium housing

TopControl Basic Type 8696

Mehr Infos



The new generation of integrated positioners for combination with small actuators from the process valve series Type 23xx/2103 is specially designed for the requirements of hygienic process environments. The operation and selection of the software functions close tight function, inversion of the operating direction of the setpoint signal, characteristic curves selection and switching manual/automatic operation are effected via push-buttons and DIP switches or via the PC interface. The position setpoint is set using the standard signal 4-20 mA. In addition, the enable can be controlled via the binary input and an optional position feedback can be integrated. The positioner, Type 8696, registers the valve end position without deterioration through a contact-free analogue position sensor. Single-acting actuators are controlled via the integral positioner system. Main customer benefits:

- Compact design of the valve system with integrated positioner meets the demands for plant washdown environments through the selection of materials, external seals and integrated control air supply to the actuator
- Automatic parameterisation of the positioner using the TUNE function
- Simple and reliable actuator adaption

Dimensions [mm]

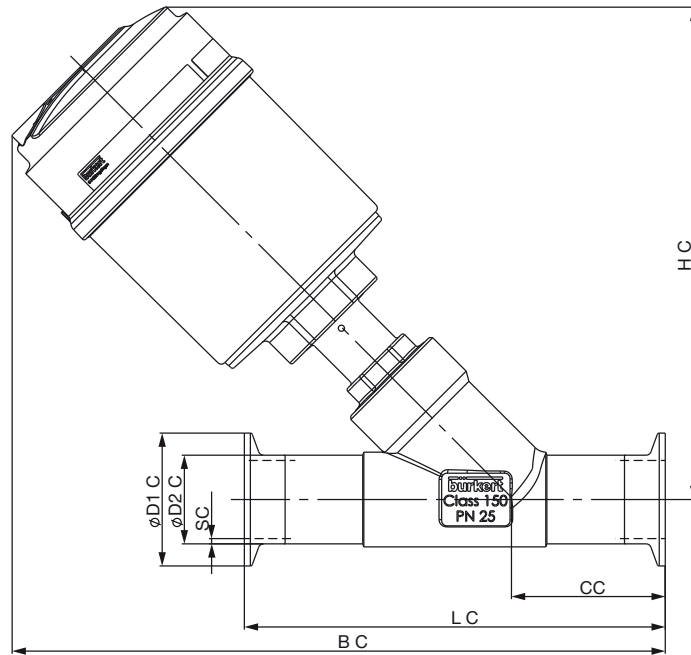

All actuators				DIN 32676 Serie B					DIN 32676 Serie A				
DN	Actuator size (ø)	HC	BC	CC	LC	ø D1C	ø D2C	SC	CC	LC	ø D1C	ø D2C	SC
15	D (50)	160	211	49*	130*	34*	21.3*	1.6*	49.5	130	34	19	1.5
	M (70)	175	227										
20	D (50)	167	226	56.5	150	50.5	26.9	1.6	57	150	34	23	1.5
	M (70)	182	242										
25	D (50)	172	232	58	160	50.5	33.7	2	58.5	160	50.5	29	1.5
	M (70)	188	248										
	N (90)	226	286										
32	M (70)	195	261	57.5*	180*	50.5*	42.4*	2*	58	180	50.5	35	1.5
	N (90)	240	303										
	P (130)	291	353										
40	N (90)	245	316	69	200	64	48.3	2	69.5	200	50.5	41	1.5
	P (130)	296	365										
50	N (90)	260	339	77.5	230	77.5	60.3	2.6	78	230	64	53	1.5
	P (130)	311	389										

* similar to DIN 32676 (ISO 2852 old)

All actuators				BS 4825-3					ASME BPE				
DN	Actuator size (ø)	HC	BC	CC	LC	ø D1C	ø D2C	SC	CC	LC	ø D1C	ø D2C	SC
15	D (50)	163	215	49	130	25.2	12.7	1.2	49	130	25	12.7	1.65
	M (70)	178	231										
20	D (50)	171	230	56.5	150	25.2	19.05	1.2	56.5	150	25	19.05	1.65
	M (70)	186	246										
25	D (50)	172	233	58	160	50.5	25.4	1.65	58	160	50.5	25.4	1.65
	M (70)	188	249										
	N (90)	227	286										
40	N (90)	245	316	69	200	50.5	38.1	1.65	69	200	50.5	38.1	1.65
	P (130)	296	365										
50	N (90)	261	340	77.5	230	64	50.8	1.65	77.5	230	64	50.8	1.65
	P (130)	312	389										

Dimensions for valve system Continuous ELEMENT Type 8802-YG [mm]

Dimensions valve system Continuous ELEMENT Type 8802-YG-I with positioner TopControl Type 8692 or 8802-YG-J with process controller TopControl Type 8693

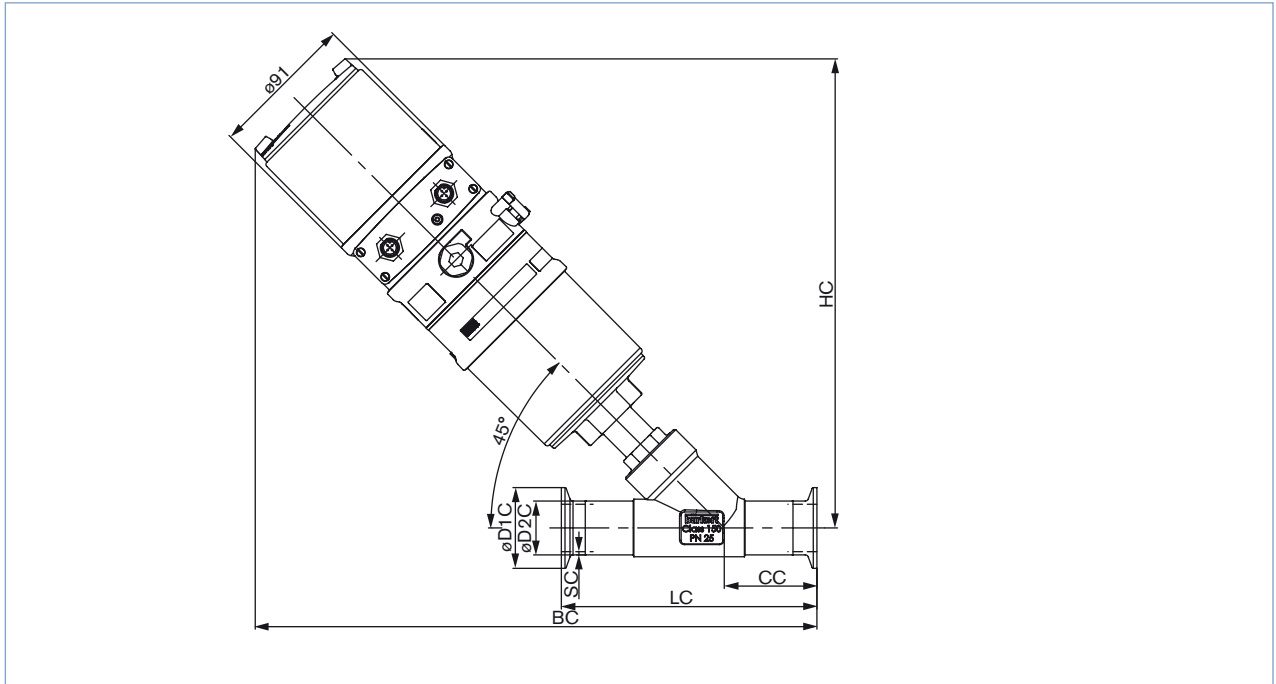

Orifice [mm]	Actua- tor size [mm]	HC	BC	LC	ISO 2852				DIN 32676				BS 4825				ASME BPE			
					CC	ØD1C	ØD2C	SC	CC	ØD1C	ØD2C	SC	CC	ØD1C	ØD2C	SC	CC	ØD1C	ØD2C	SC
15	70	285	338	130	49	34	21.3	1.6	49.5	34	19	1.5	49	25.2	12.7	1.2	49	25	12.7	1.65
20	70	293	353	150	56.5	50.5	26.9	1.6	57	34	23	1.5	56.5	25.2	19.05	1.2	56.5	25	19.05	1.65
25	70	295	356	160	58	50.5	33.7	2	58.5	50.5	29	1.5	58	50.5	25.4	1.65	58	50.5	25.4	1.65
	90	332	391	160	58	50.5	33.7	2	58.5	50.5	29	1.5	58	50.5	25.4	1.65	58	50.5	25.4	1.65
32	70	304	365	180	57.5	50.5	42.4	2	58	50.5	35	1.5	-	-	-	-	-	-	-	-
	90	347	405	180	57.5	50.5	42.4	2	58	50.5	35	1.5	-	-	-	-	-	-	-	-
40	90	350	421	200	69	64	48.3	2	69.5	50.5	41	1.5	69	50.5	38.1	1.65	69	50.5	38.1	1.65
	130	387	456	200	69	64	48.3	2	69.5	50.5	41	1.5	69	50.5	38.1	1.65	69	50.5	38.1	1.65
50	90	366	445	230	77.5	77.5	60.3	2.6	78	64	53	1.5	77.5	64	50.8	1.65	77.5	64	50.8	1.65
	130	403	480	230	77.5	77.5	60.3	2.6	78	64	53	1.5	77.5	64	50.8	1.65	77.5	64	50.8	1.65

Dimensions for valve system Continuous ELEMENT Type 8802-YG [mm], continued

Dimensions valve system Continuous ELEMENT Type 8802-YG-L with positioner TopControl Basic Type 8694

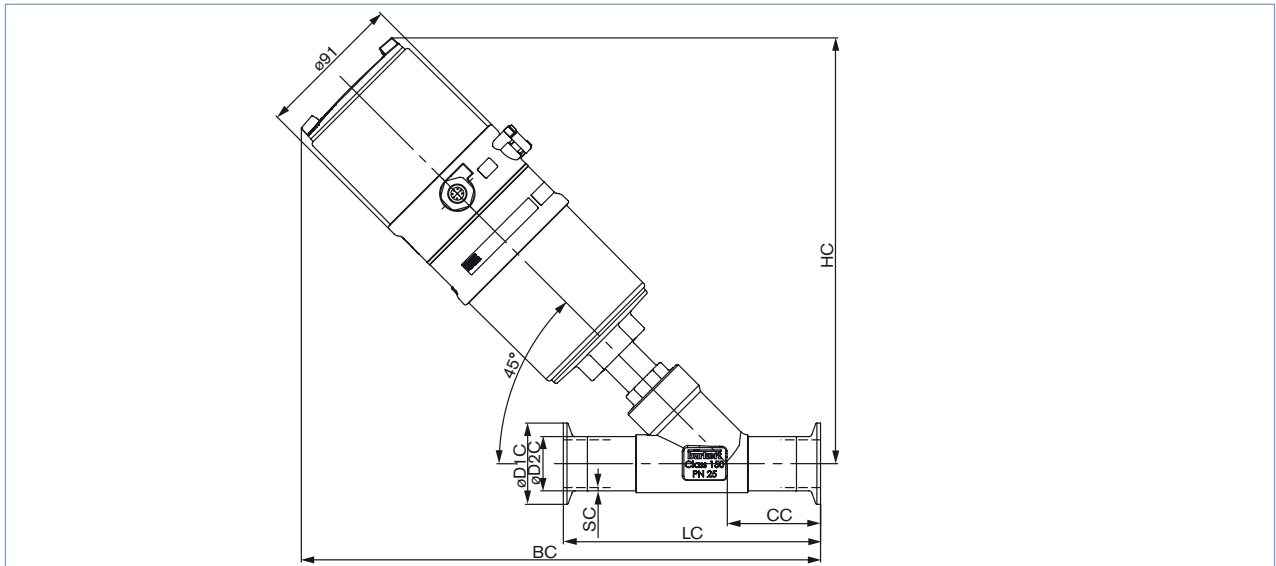

Orifice [mm]	Actuator size [mm]	ISO 2852		DIN 32676				BS 4825				ASME BPE								
		HC	BC	LC	CC	Ø D1C	Ø D2C	SC	CC	Ø D1C	Ø D2C	SC	CC	Ø D1C	Ø D2C	SC				
15	70	256	309	130	49	34	21.3	1.6	49.5	34	19	1.5	49	25.2	12.7	1.2	49	25	12.7	1.65
20	70	264	324	150	56.5	50.5	26.9	1.6	57	34	23	1.5	56.5	25.2	19.05	1.2	56.5	25	19.05	1.65
25	70	266	327	160	58	50.5	33.7	2	58.5	50.5	29	1.5	58	50.5	25.4	1.65	58	50.5	25.4	1.65
	90	303	362	160	58	50.5	33.7	2	58.5	50.5	29	1.5	58	50.5	25.4	1.65	58	50.5	25.4	1.65
32	70	275	336	180	57.5	50.5	42.4	2	58	50.5	35	1.5	-	-	-	-	-	-	-	-
	90	318	376	180	57.5	50.5	42.4	2	58	50.5	35	1.5	-	-	-	-	-	-	-	-
40	90	321	392	200	69	64	48.3	2	69.5	50.5	41	1.5	69	50.5	38.1	1.65	69	50.5	38.1	1.65
	130	358	427	200	69	64	48.3	2	69.5	50.5	41	1.5	69	50.5	38.1	1.65	69	50.5	38.1	1.65
50	90	337	416	230	77.5	77.5	60.3	2.6	78	64	53	1.5	77.5	64	50.8	1.65	77.5	64	50.8	1.65
	130	374	451	230	77.5	77.5	60.3	2.6	78	64	53	1.5	77.5	64	50.8	1.65	77.5	64	50.8	1.65

Dimensions valve system Continuous ELEMENT Type 8802-YG-N with positioner TopControl Basic Type 8696

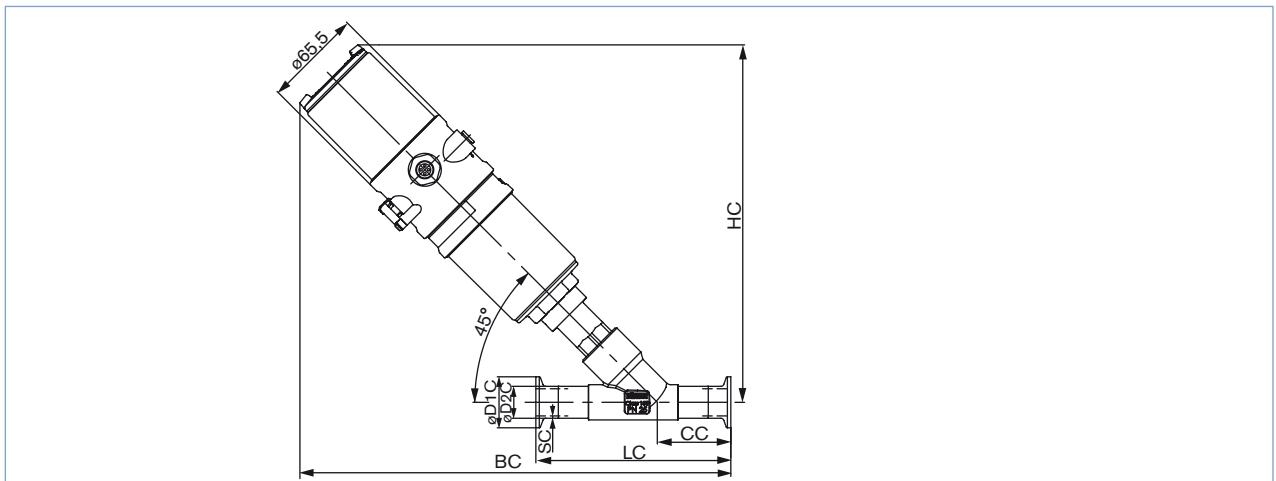

Orifice [mm]	Actuator size [mm]	ISO 2852		DIN 32676				BS 4825				ASME BPE								
		HC	BC	LC	CC	Ø D1C	Ø D2C	SC	CC	Ø D1C	Ø D2C	SC	CC	Ø D1C	Ø D2C	SC				
15	50	239	291	130	49	34	21.3	1.6	49.5	34	19	1.5	49	25.2	12.7	1.2	49	25	12.7	1.65
20	50	247	306	150	56.5	50.5	26.9	1.6	57	34	23	1.5	56.5	25.2	19.05	1.2	56.5	25	19.05	1.65
25	50	248	309	160	58	50.5	33.7	2	58.5	50.5	29	1.5	58	50.5	25.4	1.65	-	-	-	-

Dimensions for valve system Continuous ELEMENT Type 8802-YG [mm], continued

Dimensions valve system Continuous ELEMENT Type 8802-YG-P with positioner SideControl Remote Type 8792 and Type 8802-YG-Q with Process Controller SideControl Remote Type 8793

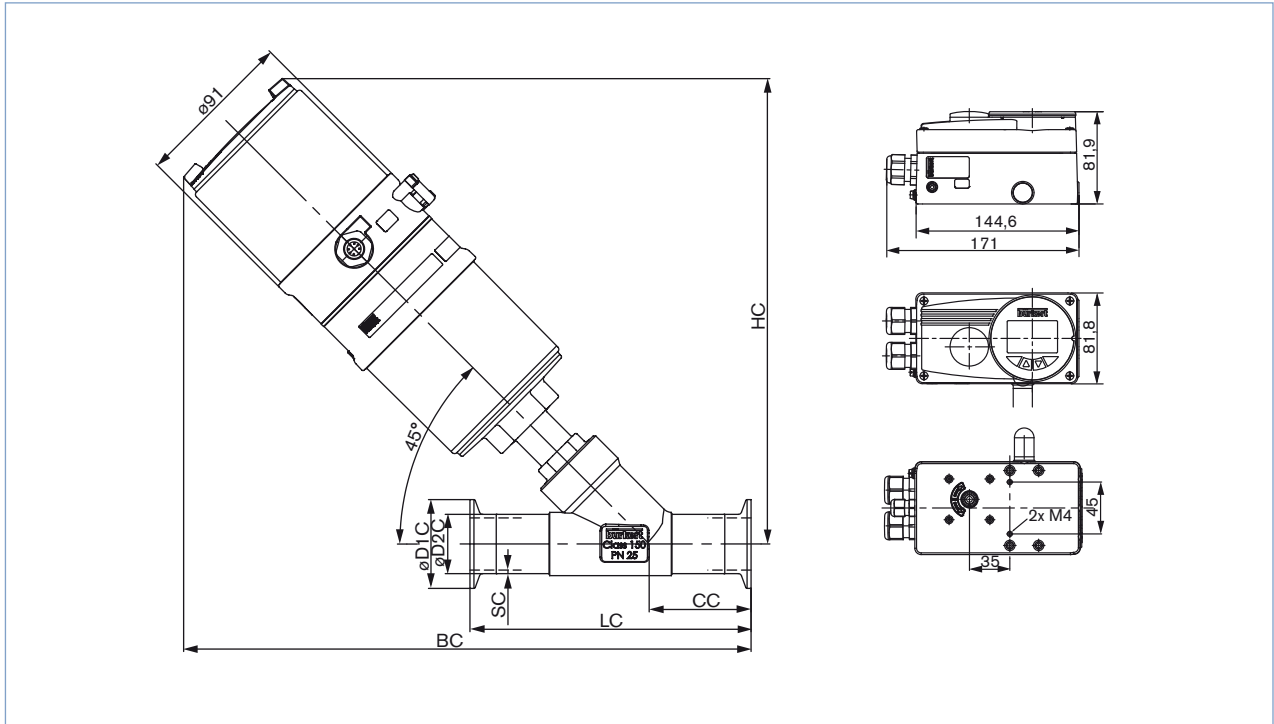

Orifice [mm]	Actuator size [mm]					ISO 2852				DIN 32676				BS 4825				ASME BPE			
		HC	BC	LC	CC	Ø D1C	Ø D2C	SC	CC	Ø D1C	Ø D2C	SC	CC	Ø D1C	Ø D2C	SC	CC	Ø D1C	Ø D2C	SC	
15	70	256	309	130	49	34	21.3	1.6	49.5	34	19	1.5	49	25.2	12.7	1.2	49	25	12.7	1.65	
20	70	264	324	150	56.5	50.5	26.9	1.6	57	34	23	1.5	56.5	25.2	19.05	1.2	56.5	25	19.05	1.65	
25	70	266	327	160	58	50.5	33.7	2	58.5	50.5	29	1.5	58	50.5	25.4	1.65	58	50.5	25.4	1.65	
	90	303	362	160	58	50.5	33.7	2	58.5	50.5	29	1.5	58	50.5	25.4	1.65	58	50.5	25.4	1.65	
32	70	275	336	180	57.5	50.5	42.4	2	58	50.5	35	1.5	-	-	-	-	-	-	-	-	
	90	318	376	180	57.5	50.5	42.4	2	58	50.5	35	1.5	-	-	-	-	-	-	-	-	
40	90	321	392	200	69	64	48.3	2	69.5	50.5	41	1.5	69	50.5	38.1	1.65	69	50.5	38.1	1.65	
	130	358	427	200	69	64	48.3	2	69.5	50.5	41	1.5	69	50.5	38.1	1.65	69	50.5	38.1	1.65	
50	90	337	416	230	77.5	77.5	60.3	2.6	78	64	53	1.5	77.5	64	50.8	1.65	77.5	64	50.8	1.65	
	130	374	451	230	77.5	77.5	60.3	2.6	78	64	53	1.5	77.5	64	50.8	1.65	77.5	64	50.8	1.65	

Note

You can fill out the fields directly in the PDF file before printing out the form.

Valve system Continuous ELEMENT Type 8802-YG - Request for quotation

▶ Please fill out and send to your nearest Bürkert facility* with your inquiry or order

Company	Contact person
Customer no.	Department
Address	Tel./Fax
Postcode/town	E-mail

= mandatory fields to fill out

Quantity

Required delivery date

Operating data

Pipe line	DN	<input type="text"/>	PN	<input type="text"/>
Pipe material	<input type="text"/>			
Process medium	<input type="text"/>			
Type of medium	<input type="checkbox"/> Liquid	<input type="checkbox"/> Steam	<input type="checkbox"/> Gas	
	min	standard	max	unit
Flow rate (Q, Q _N , W) ¹⁾	<input type="text"/>	<input type="text"/>	<input type="text"/>	<input type="text"/>
Temperature at valve inlet T1	<input type="text"/>	<input type="text"/>	<input type="text"/>	<input type="text"/>
Absolute pressure at valve inlet P1	<input type="text"/>	<input type="text"/>	<input type="text"/>	<input type="text"/>
Absolute pressure at valve outlet P2	<input type="text"/>	<input type="text"/>	<input type="text"/>	<input type="text"/>
Steam pressure P _v	<input type="text"/>	<input type="text"/>	<input type="text"/>	<input type="text"/>
Kinematic viscosity (ν)	<input type="text"/>	mm ² /s or cSt		
Dynamic viscosity (η)	<input type="text"/>	mPa.s or cP		
Standard density	<input type="text"/>	Kg/m ³		
Max. sound level accepted	<input type="text"/>	dB (A)		

¹⁾ standard unit: Liquid Q = m³/h; Steam W = kg/h; Gas Q_N = Nm³/h

Valve features







Plug seal material	<input type="checkbox"/> PTFE/Stainless steel	<input type="checkbox"/> Stainless steel/Stainless steel	
Nominal pressure	PN	<input type="text"/>	
Orifice	DN	<input type="text"/>	
Type of connection	<input type="checkbox"/> Threaded	<input type="checkbox"/> Welded	<input type="checkbox"/> Clamp
Standard connection	<input type="checkbox"/> ISO	<input type="checkbox"/> DIN	<input type="checkbox"/> Other <input type="text"/>
Control function	<input type="checkbox"/> NC ²⁾	<input type="checkbox"/> NO ²⁾	
Please specify iArticle no. if known:	<input type="text"/>		

²⁾ NC: normally closed by spring action; NO: normally open by spring action

Comments

* To find your nearest Bürkert facility, click on the orange box → www.burkert.com

Valve system Continuous ELEMENT Type 8802-YG - Request for quotation, continued

Control unit features		
For actuator sizes 70/90/130 mm		
<input type="checkbox"/> Positioner TopControl Type 8692 	<input type="checkbox"/> Process Controller TopControl Type 8693 	<input type="checkbox"/> Positioner TopControl Basic Type 8694 
		<input type="checkbox"/> Positioner SideControl Remote Type 8792  <input type="checkbox"/> Process Controller SideControl Remote Typ 8793 
Pneumatic function <input type="checkbox"/> Single-acting <input type="checkbox"/> Double-acting Communication <input type="checkbox"/> Profibus <input type="checkbox"/> DeviceNet Electrical connection <input type="checkbox"/> Cable gland <input type="checkbox"/> Multipol connection Feedback <input type="checkbox"/> 4-20 mA <input type="checkbox"/> 4-20 mA +2 binary outputs Initiator <input type="checkbox"/> Initiator <input type="text"/>	Pneumatic function <input type="checkbox"/> Single-acting Pilot air ports <input type="checkbox"/> Push-in connector external Ø 6 mm or ¼" <input type="checkbox"/> Thread G ⅛" Electrical connection <input type="checkbox"/> Cable gland <input type="checkbox"/> Multipol connection Feedback <input type="checkbox"/> 4-20 mA Please specify Article no. if known: <input type="text"/>	Power supply 24 V DC Communication <input type="checkbox"/> Without <input type="checkbox"/> Profibus DPV1 Feedback <input type="checkbox"/> Analogue feedback + 2 binary outputs <input type="checkbox"/> 2 binary outputs Electrical connection <input type="checkbox"/> Cable gland <input type="checkbox"/> Multipol connection Please specify Article no. if known: <input type="text"/>
For actuator size 50 mm		
<input type="checkbox"/> Positioner TopControl Basic Typ 8696 		
Pneumatic function <input type="checkbox"/> Single-acting Pilot air ports <input type="checkbox"/> Push-in connector external Ø 6 mm or ¼" <input type="checkbox"/> Thread G ⅛" Feedback <input type="checkbox"/> 4-20 mA Please specify Article no. if known: <input type="text"/>		

DTS 1000178892 EN Version: G Status: RL (released | freigegeben | valide) printed: 07.02.2018