

2/2 way Angle-Seat Control Valve with stainless steel design for medium up to +185 °C. DN15 - 65

- Excellent combination of good control characteristic and high flow rates
- High cycle life
- Clean design for optimal use in hygienic environment



Type 2300 weld can be combined with...



Type 8692/8693
Positioner / Process Controller TopControl



Type 8694
Positioner TopControl Basic



Type 8696
Positioner TopControl Basic



Type 8792/93
SideControl Remote version

In line with Bürkert's philosophy for modular valves and sensors the construction of the 2300 angle-seat valve fulfils tough criteria for process environments. Unrivalled cycle life and sealing integrity is guaranteed by the proven self adjusting spindle packing with V-seals.

The parabolic trim results in a flow characteristic approximately 35% larger than conventional control valves. It is available in either stainless steel on stainless steel or with a durable PTFE seal for tight shut-off.

The design enables the easy integration of automation modules whether they are digital electropneumatic positioner or process controller.



The fully integrated system has a compact and smooth design, integrated pneumatic lines. IP65/67 protection class and superior chemical resistance.

This system has been engineered for reliable accurate control in applications where high flow rate is an advantage.

Technical data	
Orifice	DN15 to 65
Port connections Weld acc. to Threaded port and clamp - see separate datasheets	EN ISO 1127, DIN 11850 R2, ASME BPE, SMS 3008, BS 4825
Body material	Stainless steel 316L
Nominal pressure	PN25 (Body)
Actuator material Actuator Cover	PPS Stainless steel 1.4561 (316Ti)
Plug sealing	PTFE/St.st. (PTFE/stainless steel) and St.st./St.st. (stainless steel/stainless steel)
Seat leakage IEC 534-4/ EN 1349	Shut-off class III and IV for St.st./St.st. Shut-off class VI for PTFE/St.st.
Medium	Water, alcohol, oils, fuels, hydraulic fluids, salt solution, alkali solutions, organic solvents, steam, optional fuel gas (EC Gas Appliances Directive 2009/142/EG)
Viscosity	max. 600 mm ² /s
Spindle packing	PTFE V-seals with spring compensation
Medium temperature	- 10 to + 185 °C (max. + 130 °C for PTFE/St.st. sealing)
Ambient temperature	0 to + 55 °C (when used with positioner or process controllers) 0 to + 80 °C (remote version)
Control medium	Compressed air
Relevant pilot pressure for circuit function A	Port size DN15 to 50 Port 5.5 to 7 bar size DN65 5.6 to 7 bar
Pilot air ports	Push-in connector for external Ø 6 mm or ¼" tube
Installation	As required, preferably with actuator in upright position
Surface Finish on request	standard Ra, internal ≤3.2 µm internal connection area ¹⁾ Ra ≤0.6 µm mechanical polished (cast iron external surface) internal connection area ¹⁾ Ra ≤0.6 µm electro polished (cast iron external surface)

¹⁾ In the seat area the Ra ≤0.6 µm surface finish can be higher.

Content

Valve specifications		System Continuous ELEMENT	Request for quotation
 Type 2300 weld		 Type 8802-YG	Type 8802-YG
Technical data & ordering info.	p. 1 - 6	Ordering info. & technical data	p. 7 - 12
			p. 13

Technical data Type 2300. continued

K_{vs} values water/pressure

Orifice [mm]	Actuator size [mm]	K _{vs} value water [m ³ /h]	Minimum pilot pressure [bar] **	Operating pressure up to + 185° NC [bar] **
15	50 / 70	5	5.5	16
20	50 / 70	10	5.5	10 / 16
25	50 / 70 / 90	16	5.5	5 / 12 / 16
32	70 / 90	23	5.5	6 / 16
40	90	34	5.5	12
	130	36	5.5	16
50	90	49	5.5	7
	130	53	5.5	16
65	130	90	5.6	16 (15*)

* acc. to the Pressure Equipment Directive 97/23 / EC for compressible fluids in Group 1 (hazardous gases and vapors in accordance with Article 3, Section 1.3, letter a, first dash)
 ** For NO (normally open) see charts on page 6

Flow rate: K_{vs} value water [m³/h]: Measured at +20 °C. 1 bar pressure at valve inlet and free outlet.
Pressure values [bar]: Overpressure to the atmospheric pressure

Flow characteristic

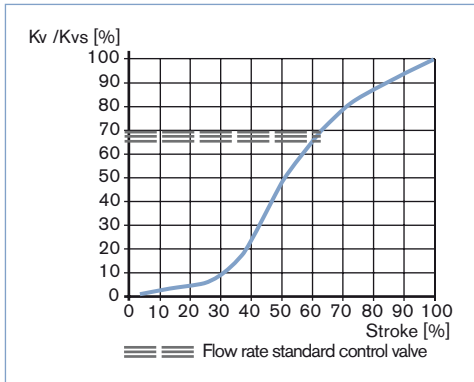

Remarks on the flow characteristic
 Modified equi-percentile flow characteristic. engineered for a quick response during peak flow demand (an advantage for many processes like heating/cooling with heat exchangers) and fine control at lower flow.

K_{vs} values [m³/h]

Orifice [mm]	Actuator size [mm]	Stroke [%]										
		5	10	20	30	40	50	60	70	80	90	100
15	50 / 70	0.16	0.17	0.22	0.4	1.2	2.7	3.5	4.0	4.5	4.8	5
20	50 / 70	0.26	0.27	0.4	1.1	4.0	5.9	7.2	8.3	9.1	9.6	10
25	50 / 70 / 90	0.34	0.36	0.62	1.5	5.2	8.9	11.5	13.0	14.2	15.4	16
32	70 / 90	0.43	0.52	0.82	1.4	4.0	9.3	13.8	16.4	19.2	21.3	23
40	90	0.47	0.62	1.1	2.6	10.0	17.0	21.5	25.3	28.8	31.6	34
	130	0.48	0.66	1.4	5.1	14.0	20.0	24.3	28.3	31.7	34.5	36
50	90	0.85	1.1	1.6	2.7	10.2	20.0	28.6	35.6	40.6	45.0	49
	130	0.87	1.2	1.8	4.0	15.2	26.0	35.0	40.3	45.0	48.0	53
65	130	1.7	2	6.5	20	35	48	58	67	75	83	90

Ordering chart Type 2300. flow direction below the seat (for gases and liquids)

Welded connection acc. to EN ISO 1127

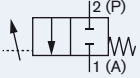
Control function	Orifice [mm]	Actuator size Ø [mm]	Port connection tube-Ø [mm]	K _{vs} value water [m³/h]	Operating pressure up to +185 °C [bar]	Article no. plug sealing PTFE/St. st.	Leakage class	Article no. plug sealing St. st./St. st.	Leakage class
A Pneumatically operated control valve, normally closed by spring force, flow direction below seat 	15	50	21.3×1.6	5	16	203565	VI	206250	IV
		70	21.3×1.6	5	16	203566	VI	206252	IV
	20	50	26.9×1.6	10	10	203567	VI	206253	III
		70	26.9×1.6	10	16	203568	VI	206254	IV
	25	50	33.7×2	16	5	203569	VI	206255	III
		70	33.7×2	16	12	203570	VI	206256	III
		90	33.7×2	16	16	245395	VI	245403	IV
	32	70	42.4×2	23	6	203571	VI	206257	III
		90	42.4×2	23	16	204766	VI	245404	IV
	40	90	48.3×2	34	12	203572	VI	206258	III
		130	48.3×2	36	16	223299	VI	223306	IV
	50	90	60.3×2.0	49	7	274669	VI	274670	III
		130	60.3×2.0	53	16	274672	VI	274673	IV
	65	130	76.1×2.3	90	16 (15*)	239490	VI	217770	IV
	B Pneumatically operated control valve, normally open by spring force, flow direction above seat	15	50	21.3×1.6	5	See charts on page 6	203574	VI	223340
70			21.3×1.6	5	203575		VI	223341	IV
20		50	26.9×1.6	10	203576		VI	223342	III
		70	26.9×1.6	10	203577		VI	223343	IV
25		50	33.7×2	16	203578		VI	223344	III
		70	33.7×2	16	203579		VI	223345	III
32		70	42.4×2	23	203580		VI	223346	III
40		90	48.3×2	34	203581		VI	223347	IV
50		90	60.3×2.0	49	274674		VI	274675	III
65		130	76.1×2.3	90	239498		VI	239515	IV

Welded connection acc. to DIN 11850 S2

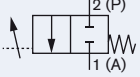
Control function	Orifice [mm]	Actuator size Ø [mm]	Port connection tube-Ø [mm]	K _{vs} value water [m³/h]	Operating pressure up to +185 °C [bar]	Article no. plug sealing PTFE/St. st.	Leakage class	Article no. plug sealing St. st./St. st.	Leakage class
A Pneumatically operated control valve, normally closed by spring force, flow direction below seat 	15	50	19×1.5	5	16	203583	VI	223349	IV
		70	19×1.5	5	16	203584	VI	223350	IV
	20	50	23×1.5	10	10	203585	VI	223351	III
		70	23×1.5	10	16	203586	VI	223352	IV
	25	50	29×1.5	16	5	203587	VI	223353	III
		70	29×1.5	16	12	203588	VI	223354	III
		90	29×1.5	16	16	245396	VI	245409	IV
	32	70	35×1.5	23	6	203589	VI	223355	III
		90	35×1.5	23	16	204767	VI	245410	IV
	40	90	41×1.5	34	12	203590	VI	223356	III
		130	41×1.5	36	16	223300	VI	223357	IV
	50	90	53×1.5	49	7	203591	VI	223358	III
		130	53×1.5	53	16	213702	VI	223359	IV
	65	130	70×2	90	16 (15*)	239491	VI	239507	IV
	B Pneumatically operated control valve, normally open by spring force, flow direction above seat	15	50	19×1.5	5	See charts on page 6	203592	VI	223360
70			19×1.5	5	203593		VI	223361	IV
20		50	23×1.5	10	203594		VI	223362	III
		70	23×1.5	10	203595		VI	223363	IV
25		50	29×1.5	16	203596		VI	223364	III
		70	29×1.5	16	203597		VI	223365	III
32		70	35×1.5	23	203598		VI	223366	III
40		90	41×1.5	34	203599		VI	223367	IV
50		90	53×1.5	49	203600		VI	223368	III
65		130	70×2	90	239499		VI	239516	IV

* acc. to the Pressure Equipment Directive 97/23 / EC for compressible fluids in Group 1 (hazardous gases and vapors in accordance with Article 3, Section 1.3, letter a, first dash)

Ordering chart Type 2300. flow direction below the seat (for gases and liquids). continued

Welded connection acc. to ASME BPE

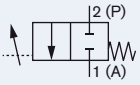
Control function	Orifice [mm]	Actuator size Ø [mm]	Port connection tube-Ø [mm]	K _{vs} value water [m³/h]	Operating pressure up to +185 °C [bar]	Article no. plug sealing PTFE/St. st.	Leakage class	Article no. plug sealing St. st./St. st.	Leakage class	
A Pneumatically operated control valve, normally closed by spring force, flow direction below seat 	15	50	12.7 × 1.65	5	16	203601	VI	223369	IV	
		70	12.7 × 1.65	5	16	203602	VI	223370	IV	
	20	50	19.05 × 1.65	10	10	203603	VI	223371	III	
		70	19.05 × 1.65	10	16	203604	VI	223372	IV	
	25	50	25.4 × 1.65	16	5	203637	VI	223373	III	
		70	25.4 × 1.65	16	12	203606	VI	223374	III	
		90	25.4 × 1.65	16	16	245397	VI	245411	IV	
	40	90	38.1 × 1.65	34	12	203607	VI	212906	III	
		130	38.1 × 1.65	36	16	223303	VI	223376	IV	
	50	90	50.8 × 1.65	49	7	203608	VI	223377	III	
		130	50.8 × 1.65	53	16	213703	VI	223378	IV	
	65	130	63.5 × 1.65	90	16 (15*)	239492	VI	239508	IV	
	B Pneumatically operated control valve, normally open by spring force, flow direction above seat	15	50	12.7 × 1.65	5	see charts on page 6	203609	VI	223379	IV
			70	12.7 × 1.65	5		203610	VI	223380	IV
20		50	19.05 × 1.65	10	203611		VI	223381	III	
		70	19.05 × 1.65	10	203612		VI	223382	IV	
25		50	25.4 × 1.65	16	203645		VI	223383	III	
		70	25.4 × 1.65	16	203614		VI	223384	III	
40		90	38.1 × 1.65	34	203615		VI	223385	IV	
50		90	50.8 × 1.65	49	203616		VI	223386	III	
65		130	63.5 × 1.65	90	239500		VI	239517	IV	

Welded connection acc. to SMS 3008

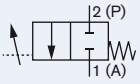
Control function	Orifice [mm]	Actuator size Ø [mm]	Port connection tube-Ø [mm]	K _{vs} value water [m³/h]	Operating pressure up to +185 °C [bar]	Article no. plug sealing PTFE/ St. st.	Leakage class	Article no. plug sealing St. st./St. st.	Leakage class	
A Pneumatically operated control valve, normally closed by spring force, flow direction below seat 	15	50	12 × 1.0	5	16	203617	VI	223387	IV	
		70	12 × 1.0	5	16	203618	VI	223388	IV	
	20	50	18 × 1.0	10	10	203619	VI	223389	III	
		70	18 × 1.0	10	16	203620	VI	223390	IV	
	25	50	25 × 1.2	16	5	203621	VI	223391	III	
		70	25 × 1.2	16	12	203622	VI	223392	III	
		90	25 × 1.2	16	16	245398	VI	245412	IV	
	40	90	38 × 1.2	34	12	203623	VI	223393	III	
		130	38 × 1.2	36	16	223302	VI	223394	IV	
	50	90	51 × 1.2	49	7	203624	VI	223395	III	
		130	51 × 1.2	53	16	213704	VI	223396	IV	
	65	130	63.5 × 1.65	90	16 (15*)	239493	VI	239509	IV	
	B Pneumatically operated control valve, normally open by spring force, flow direction above seat	15	50	12 × 1.0	5	see charts on page 6	203625	VI	223397	IV
			70	12 × 1.0	5		203626	VI	223398	IV
20		50	18 × 1.0	10	203627		VI	223399	III	
		70	18 × 1.0	10	203628		VI	223400	IV	
25		50	25 × 1.2	16	203629		VI	223401	III	
		70	25 × 1.2	16	203630		VI	223402	III	
40		90	38 × 1.2	34	203631		VI	223403	IV	
50		90	51 × 1.2	49	203632		VI	223404	III	
65		130	63.5 × 1.65	90	239501		VI	239518	IV	

* acc. to the Pressure Equipment Directive 97/23 / EC for compressible fluids in Group 1 (hazardous gases and vapors in accordance with Article 3, Section 1.3, letter a, first dash)

Ordering chart Type 2300. flow direction below the seat (for gases and liquids) continued

Welded connection acc. to BS 4825

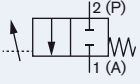
Control function	Orifice [mm]	Actuator size Ø [mm]	Port connection tube-Ø [mm]	K _{vs} value water [m³/h]	Operating pressure up to +185 °C [bar]	Article no. plug sealing PTFE/St. st.	Leakage class	Article no. plug sealing St. st./St. st.	Leakage class
A Pneumatically operated control valve, normally closed by spring force, flow direction below seat 	15	50	12.7 × 1.2	5	16	203633	VI	223405	IV
		70	12.7 × 1.2	5	16	203634	VI	223406	IV
	20	50	19.05 × 1.65	10	10	203635	VI	223407	III
		70	19.05 × 1.65	10	16	203636	VI	223408	IV
	25	50	25.4 × 1.65	16	5	203637	VI	223373	III
		70	25.4 × 1.65	16	12	203606	VI	212907	III
		90	25.4 × 1.65	16	16	245397	VI	245413	IV
	40	90	38.1 × 1.65	34	12	203607	VI	212906	III
		130	38.1 × 1.65	36	16	223303	VI	223412	IV
	50	90	50.8 × 1.65	49	7	203608	VI	212904	III
		130	50.8 × 1.65	53	16	213703	VI	223414	IV
	65	130	63.5 × 1.65	90	16	239492	VI	239508	IV
B Pneumatically operated control valve, normally open by spring force, flow direction above seat	15	50	12.7 × 1.2	5	see charts on page 6	203641	VI	223415	IV
		70	12.7 × 1.2	5		203642	VI	223416	IV
	20	50	19.05 × 1.65	10		203643	VI	223417	III
		70	19.05 × 1.65	10		203644	VI	223418	IV
	25	50	25.4 × 1.65	16		203645	VI	223383	III
		70	25.4 × 1.65	16		203614	VI	223384	III
	40	90	38.1 × 1.65	34		203615	VI	223385	IV
	50	90	50.8 × 1.65	49		203616	VI	223386	III
	65	130	63.5 × 1.65	90		239500	VI	239517	IV

* acc. to the Pressure Equipment Directive 97/23 / EC for compressible fluids in Group 1 (hazardous gases and vapors in accordance with Article 3, Section 1.3, letter a, first dash)

Materials Type 2300

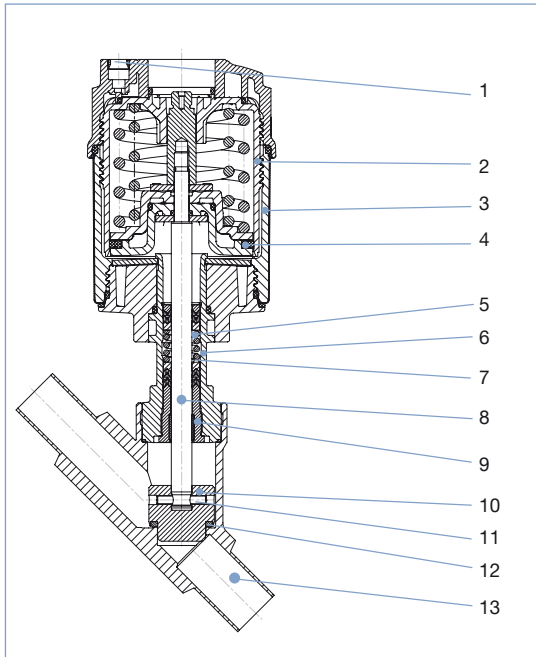

1	Pilot air ports	Push-in connector PP (standard)
2	Actuator	PPS
3	Cover	Stainless steel 1.4561 (316Ti)
4	Piston seal	FKM
5	Spring	Stainless steel 1.4310
6	Tube	Stainless steel 1.4401 (316) / 1.4404 (316L)
7	Spindle packing	PTFE
8	Spindle	Stainless steel 1.4401 (316) / 1.4404 (316L)
9	Spindle guidance	Edelstahl 1.4404 (316L)
10	Plug	Stainless steel 1.4571
11	Spring straight pin	Stainless steel 1.4310
12	Plug seal	Stainless steel 1.4571 / PTFE disc for soft seat sealing
13	Valve body	Stainless steel 316L

Pressure Charts with control function B (normally open. NO)

Ø 50

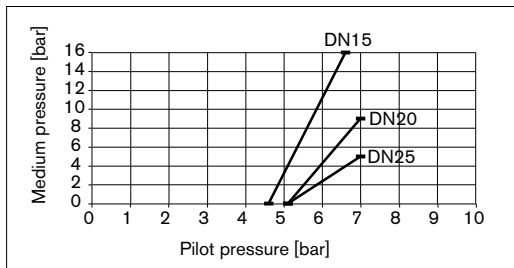

Ø 70

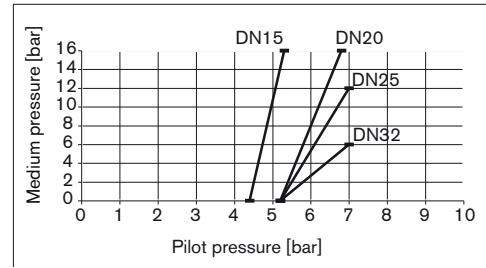

Ø 90

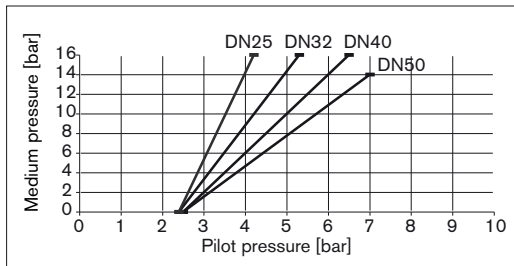

Ø 130

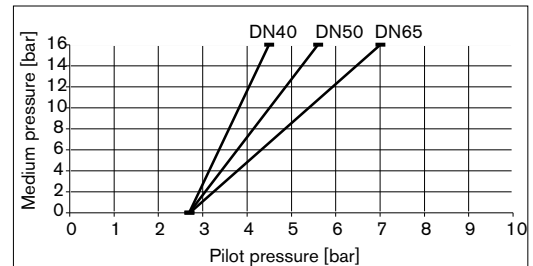

Ordering information for valve system Continuous ELEMENT Type 8802-YG

A valve system Continuous ELEMENT Type 8802-YG consists of an angle-seat control valve Type 2300 and a digital electropneumatic Positioner Type 8692, a digital electropneumatic Process Controller Type 8693, a digital electropneumatic Positioner Basic Type 8694 (below), an electropneumatic Positioner Type 8792/8793 (for valve actuator sizes Ø 70/90/130 mm) or a digital electropneumatic Positioner Type 8696 (for valve actuator size Ø 50 mm) (see next page and separate datasheets). For the configuration of further valve systems please use the "Request for quotation" on p. 13. You order two components and receive a complete assembled and certified valve.

Ordering the valve system Continuous ELEMENT Type 8802-YG

Angle seat valve Type 2300



Positioner



Positioner
Type 8692



Process Controller
Type 8693



Positioner Basic
Type 8694

**Angle seat valve
with desired control unit**



Valve system
Continuous
ELEMENT
Type 8802-YG-I
2300 + 8692



Valve system
Continuous
ELEMENT
Type 8802-YG-J
2300 + 8693



Valve system
Continuous
ELEMENT
Type 8802-YG-L
2300 + 8694

When you click on the orange box "More info." below, you will come to our website for the resp. product where you can download the

**Positioner TopControl
Type 8692**

More
info.

**Process Controller
TopControl Type 8693**

More
info.



DeviceNet™

The new generation of integrated positioners/process controllers for combination with actuators from the process valve series Type 23xx/2103 is specially designed for the requirements of hygienic process environments. The easy handling and the selection of additional software functions are done either on a big graphic display with backlight and keypad or via a PC interface. A contact-free analogue position sensor registers the valve position without deterioration. Single-acting or double-acting actuators are controlled via the integral positioner system. With Type 8693, the process controller function is superimposed on the position control loop. Profibus DPV1 and DeviceNet communication interfaces are available as options.

Main customer benefits:

- Compact design of the valve system with integrated positioner/process controller meets the demands for plant washdown environments through the selection of materials, external seals and integrated control air supply to the actuator
- Extremely simple commissioning and operation thanks to the backlighting of the graphics display and proven multilingual software structure
- Automatic parameterisation of the positioner and process controller using the TUNE functions
- Field bus communication via Profibus DPV1 or DeviceNet
- Air intake filter enhances the process valve system availability
- Simple and reliable actuator adaption

Positioner TopControl Basic Type 8694

More
info.



The new generation of integrated positioners for combination with actuators from the process valve series Type 23xx/2103 is specially designed for the requirements of hygienic process environments. The operation and selection of the software functions close tight function, inversion of the operating direction of the setpoint signal, characteristic curves selection and switching manual/automatic operation are effected via push-buttons and DIP switches or via the PC interface. The position setpoint is set using the standard signal 4-20 mA. In addition, the enable can be controlled via the binary input and an optional position feedback can be integrated.

The positioner, Type 8694, registers the valve position without deterioration through a contact-free analogue position sensor. Single-acting or double-acting actuators are controlled via the integral positioner system. An AS-Interface communication interface is available as an option.

Main customer benefits:

- Compact design of the valve system with integrated positioner meets the demands for plant washdown environments through the selection of materials, external seals and integrated control air supply to the actuator
- Automatic parameterisation of the positioner using the Process TUNE function
- Field bus communication via optional AS-Interface
- Air intake filter enhances the process valve system availability
- Simple and reliable actuator adaption allowing additional actuators of the process valve series, Type 20xx or actuators from other manufacturers to be used

Ordering information for valve system Continuous ELEMENT Type 8802-YG. continued

A valve system Continuous ELEMENT Type 8802-YG consists of an angle-seat control valve Type 2300 and a digital electropneumatic Positioner Type 8692, a digital electropneumatic Process Controller Type 8693, a digital electropneumatic Positioner Basic Type 8694 (previous page), an electropneumatic Positioner Type 8792/8793 (for valve actuator sizes Ø 70/90/130) mm or a digital electropneumatic Positioner Type 8696 (for valve actuator size Ø 50 mm) (see separate datasheets). For the configuration of further valve systems please use the "Request for quotation" on p. 13. You order two components and receive a complete assembled and certified valve.

Ordering the valve system Continuous ELEMENT Type 8802-YG

Angle seat valve Type 2300



Positioner



Positioner
Type 8792/
Process Controller Type 8793



TopControl Basic Type 8696
Only for actuator size
Ø 50 mm

**Angle seat valve
with desired control unit**



Valve system
Continuous ELEMENT
Type 8802-YG-P
2300 + 8792 /
Type 8802-YG-Q
2300 + 8793



Valve system
Continuous ELEMENT
Type 8802-YG-N
2300 + 8696

When you click on the orange box "More info." below, you will come to our website for the resp. product where you can download the datasheet.

Positioner SideControl Type 8792

More info.

Process Controller SideControl Type 8793

More info.



Type 8792/8793 is a digital electro-pneumatic positioner with an optional, integrated process controller (8793) for precise control requirements. The compact design with integrated position encoder and LCD display was developed for demanding applications of the process industry. A Profibus DPV1 communication interface is available as an option. Main customer benefits are:

- Time saving algorithms for temperature flow and pressure PID parameters through ProcessTUNE function
- Quick and simple menu driven parameterization through keyboard or Profibus DPV1 PA
- Adaption acc. to IEC534-6 and VDI/VDE 3845 for lift and swivel drives or as a Remote version together with Bürkert process valves
- Rugged anodised aluminium housing

TopControl Basic Type 8696

Mehr Infos



The new generation of integrated positioners for combination with small actuators from the process valve series Type 23xx/2103 is specially designed for the requirements of hygienic process environments. The operation and selection of the software functions close tight function, inversion of the operating direction of the setpoint signal, characteristic curves selection and switching manual/automatic operation are effected via push-buttons and DIP switches or via the PC interface. The position setpoint is set using the standard signal 4-20 mA. In addition, the enable can be controlled via the binary input and an optional position feedback can be integrated. The positioner, Type 8696, registers the valve end position without deterioration through a contact-free analogue position sensor. Single-acting actuators are controlled via the integral positioner system. Main customer benefits:

- Compact design of the valve system with integrated positioner meets the demands for plant washdown environments through the selection of materials, external seals and integrated control air supply to the actuator
- Automatic parameterisation of the positioner using the TUNE function
- Simple and reliable actuator adaption

Dimensions [mm]

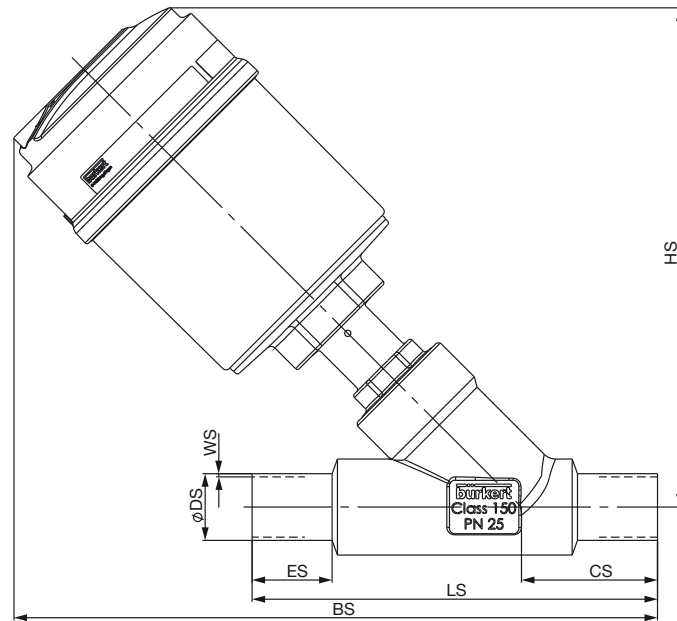

All actuators			ISO 4200					DIN 11850 Series 2					SMS 3008							
DN	Actuator size (ø)	HS	BS	CS	LS	ES	ø DS	WS	CS	LS	ES	ø DS	WS	HS	BS	CS	LS	ES	ø DS	WS
15	D (50)	160	196	34	100	19	21.3	1.6	34	100	19	19.0	1.5	163	212	46	135	30	12.0	1
	M (70)	175	212				21.3							178	228				12.0	
20	D (50)	167	209	39	115	20	26.9	1.6	39	115	20	23.0	1.5	171	225	52	145	30	18.0	1
	M (70)	182	225											186	241				18.0	
25	D (50)	172	217	43	130	26	33.7	2	43	130	26	29.0	1.5	172	226	51	152	30	25.0	1.2
	M (70)	188	233											188	242					
	N (90)	226	270											227	279					
32	M (70)	195	244	45	145	26	42.4	2	45	145	26	35.0	1.5	197	241	40	145		38.0	1.2
	N (90)	240	286											242	283					
	P (130)	291	336											293	333					
40	N (90)	245	296	49	160	26	48.3	2	49	160	26	41.0	1.5	245	307	60	182	30	38.0	1.2
	P (130)	296	345											296	356					
50	N (90)	260	311	50	175	26	60.3	2	50	175	26	53.0	1.5	261	326	64	210	30	51.0	1.2
	P (130)	311	316											312	376					
65	P (130)	342	392	50	210	26	76.1	2.3	50	210	26	70.0	2.0	342	398	56	230	26	63.5	1.65

All actuators			ASME BPE DIN 11866 Series C					BS4825 Part 1					
DN	Actuator size (ø)	HS	BS	CS	LS	ES	ø DS	WS	CS	LS	ES	ø DS	WS
15	D (50)	163	212	46	135	30	12.7	1.65	46	135	30	12.7	1.2
	M (70)	178	228										
20	D (50)	171	225	52	145	30	19.05	1.65	52	145	30	19.05	1.2
	M (70)	186	241										
25	D (50)	172	226	51	152	30	25.4	1.65	51	152	30	25.4	1.65
	M (70)	188	242										
	N (90)	227	279										
40	N (90)	245	307	60	182	30	38.1	1.65	60	182	30	38.1	1.65
	P (130)	296	356										
50	N (90)	261	326	64	210	30	50.8	1.65	64	210	30	50.8	1.65
	P (130)	312	376										
65	P (130)	342	398	56	230	26	63.5	1.65	56	230	26	63.5	1.65

Dimensions for valve system Continuous ELEMENT Type 8802-YG [mm]

Dimensions valve system Continuous ELEMENT Type 8802-YG-I with positioner TopControl Type 8692 or 8802-YG-J with process controller TopControl Type 8693

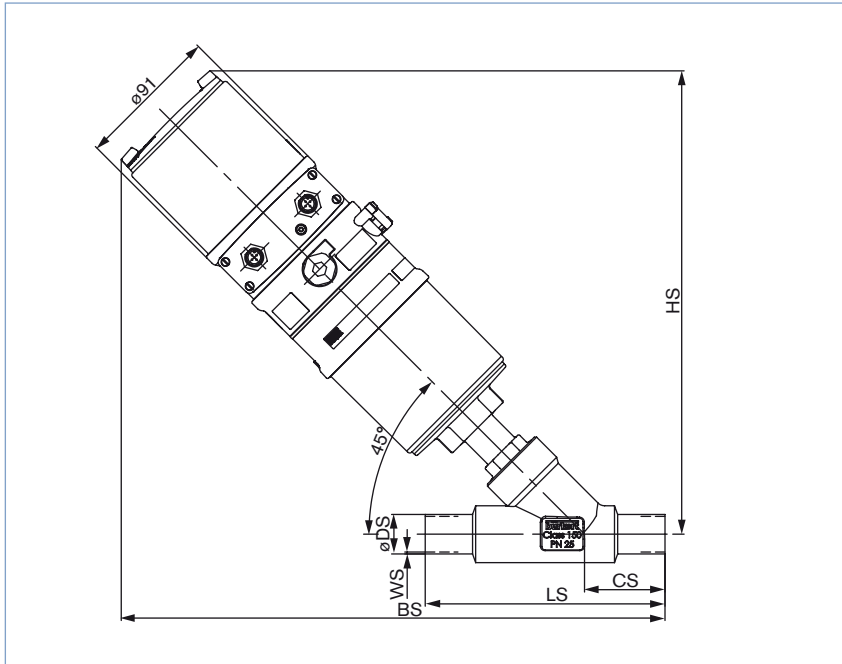

ISO 4200, DIN 11850 R2, ASME BPE

Orifice [mm]	Actuator size [mm]	HS	ISO 4200					DIN 1180 R2					ASME BPE				
			BS	CS	LS	ØDS	WS	BS	CS	LS	ØDS	WS	BS	CS	LS	ØDS	WS
15	70	285	323	34	100	21.3	1.6	323	34	100	19	1.5	323	34	100	12.7	1.65
20	70	293	335	39	115	26.9	1.6	335	39	115	23	1.5	335	39	115	19.05	1.65
25	70	295	341	43	130	33.7	2	341	43	130	29	1.5	341	43	130	25.4	1.65
	90	332	376	43	130	33.7	2	376	43	130	29	1.5	376	43	130	25.4	1.65
32	70	304	348	40	145	42.4	2	348	40	145	35	1.5	-	-	-	-	-
	90	347	388	40	145	42.4	2	388	40	145	35	1.5	-	-	-	-	-
40	90	350	401	49	160	48.3	2	401	49	160	41	1.5	401	49	160	38.1	1.65
	130	387	436	49	160	48.3	2	436	49	160	41	1.5	436	49	160	38.1	1.65
50	90	366	417	50	175	60.3	2.0	417	50	175	53	1.5	417	50	175	50.8	1.65
	130	403	453	50	175	60.3	2.0	453	50	175	53	1.5	453	50	175	50.8	1.65
65	130	433	483	50	210	76.1	2.3	483	50	210	70	2	483	56	230	63.5	1.65

SMS 3008, BS4825

Orifice [mm]	Actuator size [mm]	HS	SMS 3008					BS 4825				
			BS	CS	LS	ØDS	WS	BS	CS	LS	ØDS	WS
15	70	285	335	46	135	12	1	323	34	100	12.7	1.2
20	70	293	348	52	145	18	1	335	39	115	19.05	1.2
25	70	295	349	51	152	25	1.2	341	43	130	25.4	1.65
	90	332	384	51	152	25	1.2	376	43	130	25.4	1.65
40	90	350	412	60	182	38	1.2	401	49	160	38.1	1.65
	130	387	447	60	182	38	1.2	436	49	160	38.1	1.65
50	90	366	431	64	210	51	1.2	417	50	175	50.8	1.65
	130	403	467	64	210	51	1.2	453	50	175	50.8	1.65
65	130	433	489	56	230	63.5	1.65	483	56	230	63.5	1.65

Dimensions for valve system Continuous ELEMENT Type 8802-YG [mm]. continued

Dimensions valve system Continuous ELEMENT Type 8802-YG-L with positioner TopControl Basic Type 8694

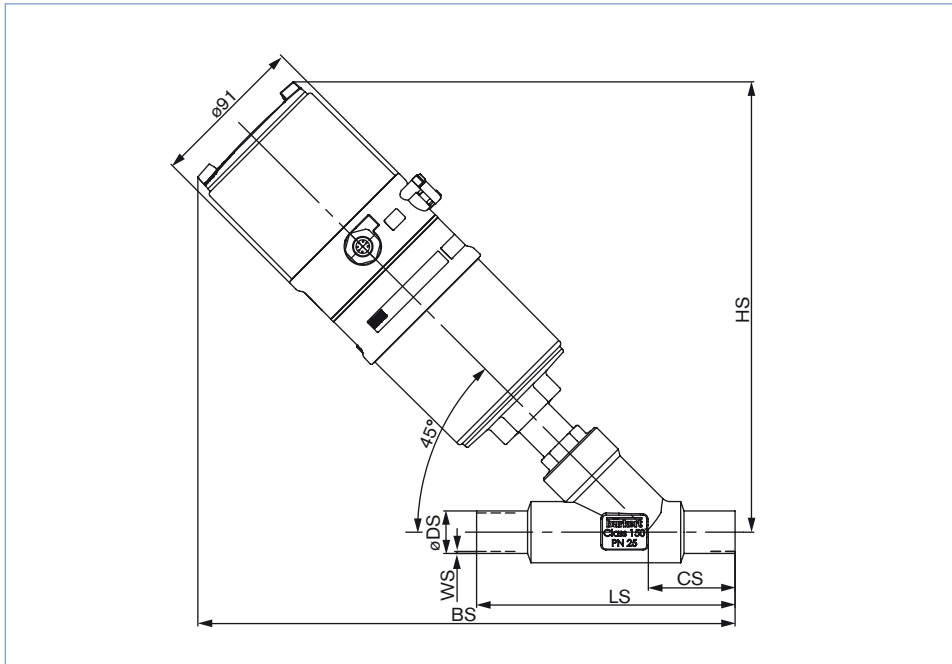

ISO 4200, DIN 11850 R2, ASME BPE

Orifice [mm]	Actuator size	ISO 4200						DIN 1180 R2					ASME BPE				
		HS	BS	CS	LS	ØDS	WS	BS	CS	LS	ØDS	WS	BS	CS	LS	ØDS	WS
15	70	256	294	34	100	21.3	1.6	294	34	100	19	1.5	294	34	100	12.7	1.65
20	70	264	306	39	115	26.9	1.6	306	39	115	23	1.5	306	39	115	19.05	1.65
25	70	266	312	43	130	33.7	2	312	43	130	29	1.5	312	43	130	25.4	1.65
	90	303	347	43	130	33.7	2	347	43	130	29	1.5	347	43	130	25.4	1.65
32	70	275	319	40	145	42.4	2	319	40	145	35	1.5	-	-	-	-	-
	90	318	359	40	145	42.4	2	359	40	145	35	1.5	-	-	-	-	-
40	90	321	372	49	160	48.3	2	372	49	160	41	1.5	372	49	160	38.1	1.65
	130	358	407	49	160	48.3	2	407	49	160	41	1.5	407	49	160	38.1	1.65
50	90	337	388	50	175	60.3	2.0	388	50	175	53	1.5	388	50	175	50.8	1.65
	130	374	424	50	175	60.3	2.0	424	50	175	53	1.5	424	50	175	50.8	1.65
65	130	404	454	50	210	76.1	2.3	454	50	210	70	2	454	56	230	63.5	1.65

SMS 3008, BS 4825

Orifice [mm]	Actuator size	HS	SMS 3008					BS 4825				
			BS	CS	LS	ØDS	WS	BS	CS	LS	ØDS	WS
15	70	256	306	46	135	12	1	294	34	100	12.7	1.2
20	70	264	319	52	145	18	1	306	39	115	19.05	1.2
25	70	266	320	51	152	25	1.2	312	43	130	25.4	1.65
	90	303	355	51	152	25	1.2	347	43	130	25.4	1.65
40	90	321	383	60	182	38	1.2	372	49	160	38.1	1.65
	130	358	418	60	182	38	1.2	407	49	160	38.1	1.65
50	90	337	402	64	210	51	1.2	388	50	175	50.8	1.65
	130	374	438	64	210	51	1.2	424	50	175	50.8	1.65
65	130	404	460	56	230	63.5	1.65	454	56	230	63.5	1.65

Dimensions for valve system Continuous ELEMENT Type 8802-YG [mm]. continued

Dimensions valve system Continuous ELEMENT Type 8802-YG-P with positioner SideControl Remote Type 8792 and Type 8802-YG-Q with Process Controller SideControl Remote Type 8793

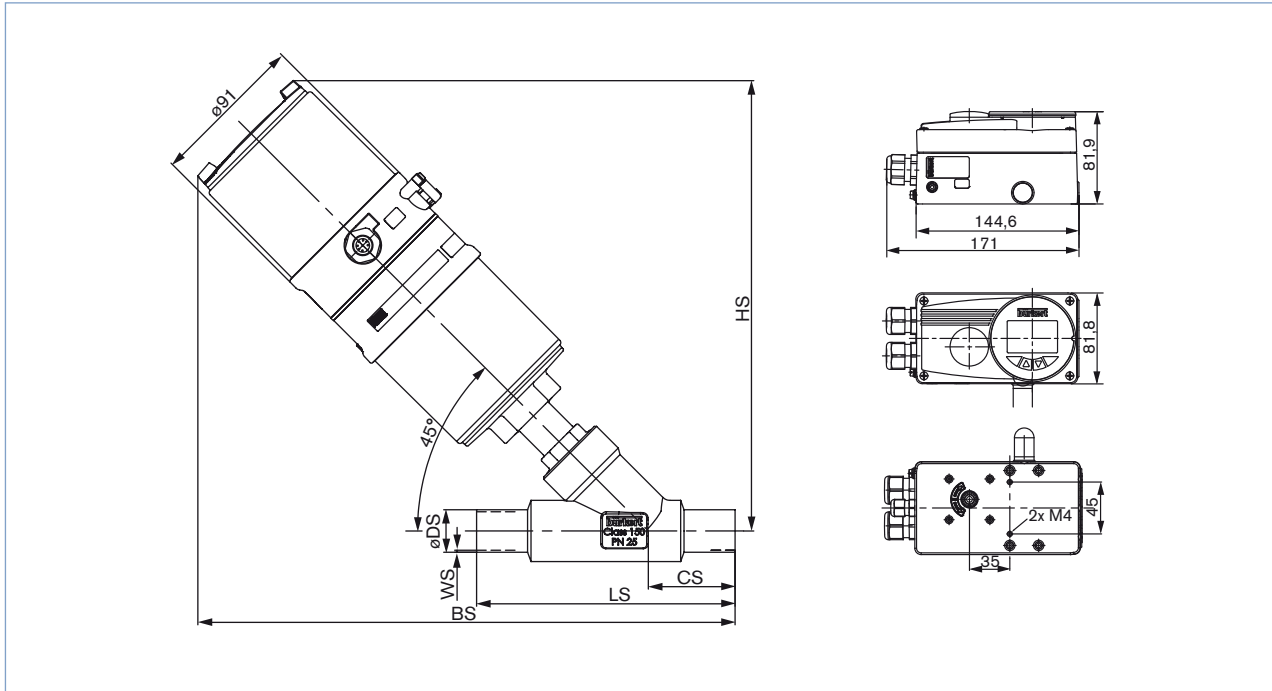

ISO 4200, DIN 11850 R2, ASME BPE,

Orifice [mm]	Actuator size	HS	ISO 4200					DIN 11850 R2					ASME BPE				
			BS	CS	LS	ØDS	WS	BS	CS	LS	ØDS	WS	BS	CS	LS	ØDS	WS
15	70	256	294	34	100	21.3	1.6	294	34	100	19	1.5	294	34	100	12.7	1.65
20	70	264	306	39	115	26.9	1.6	306	39	115	23	1.5	306	39	115	19.05	1.65
25	70	266	312	43	130	33.7	2	312	43	130	29	1.5	312	43	130	25.4	1.65
	90	303	347	43	130	33.7	2	347	43	130	29	1.5	347	43	130	25.4	1.65
32	70	275	319	40	145	42.4	2	319	40	145	35	1.5	-	-	-	-	-
	90	318	359	40	145	42.4	2	359	40	145	35	1.5	-	-	-	-	-
40	90	321	372	49	160	48.3	2	372	49	160	41	1.5	372	49	160	38.1	1.65
	130	358	407	49	160	48.3	2	407	49	160	41	1.5	407	49	160	38.1	1.65
50	90	337	388	50	175	60.3	2.0	388	50	175	53	1.5	388	50	175	50.8	1.65
	130	374	424	50	175	60.3	2.0	424	50	175	53	1.5	424	50	175	50.8	1.65
65	130	404	454	50	210	76.1	2.3	454	50	210	70	2	454	56	230	63.5	1.65

SMS 3008, BS 4825

Orifice [mm]	Actuator size	HS	SMS 3008					BS 4825				
			BS	CS	LS	ØDS	WS	BS	CS	LS	ØDS	WS
15	70	256	306	46	135	12	1	294	34	100	12.7	1.2
20	70	264	319	52	145	18	1	306	39	115	19.05	1.2
25	70	266	320	51	152	25	1.2	312	43	130	25.4	1.65
	90	303	355	51	152	25	1.2	347	43	130	25.4	1.65
40	90	321	383	60	182	38	1.2	372	49	160	38.1	1.65
	130	358	418	60	182	38	1.2	407	49	160	38.1	1.65
50	90	337	402	64	210	51	1.2	388	50	175	50.8	1.65
	130	374	438	64	210	51	1.2	424	50	175	50.8	1.65
65	130	404	460	56	230	63.5	1.65	454	56	230	63.5	1.65

Dimensions for valve system Continuous ELEMENT Type 8802-YG [mm]. continued

Dimensions valve system Continuous ELEMENT Type 8802-YG-N with positioner TopControl Basic Type 8696

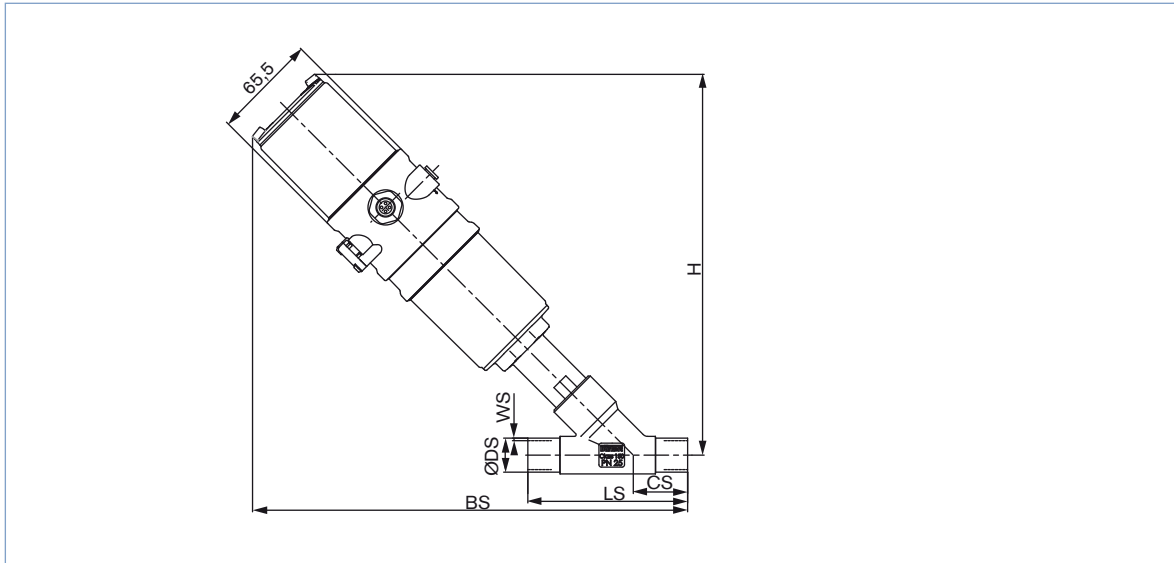

ISO 4200, DIN 11850 R2, ASME BPE

Orifice [mm]	Actuator size	HS	ISO 4200					DIN 1180 R2					ASME BPE				
			BS	CS	LS	ØDS	WS	BS	CS	LS	ØDS	WS	BS	CS	LS	ØDS	WS
15	50	239	276	34	100	21.3	1.6	276	34	100	19	1.5	276	34	100	12.7	1.65
20	50	247	288	39	115	26.9	1.6	288	39	115	23	1.5	288	39	115	19.05	1.65
25	50	248	294	43	130	33.7	2	294	43	130	29	1.5	294	43	130	25.4	1.65

SMS 3008 , BS4825

Orifice [mm]	Actuator size	HS	SMS 3008					BS 4825				
			BS	CS	LS	ØDS	WS	BS	CS	LS	ØDS	WS
15	50	239	288	46	135	12	1	276	34	100	12.7	1.2
20	50	247	301	52	145	18	1	288	39	115	19.05	1.2
25	50	248	302	51	152	25	1.2	294	43	130	25.4	1.65

Note

You can fill out the fields directly in the PDF file before printing out the form.

Valve system Continuous ELEMENT Type 8802-YG - Request for quotation

▶ Please fill out and send to your nearest Bürkert facility* with your inquiry or order

Company	Contact person
Customer no.	Department
Address	Tel./Fax
Postcode/town	E-mail

= mandatory fields to fill out

Quantity

Required delivery date

Operating data

Pipe line	DN	<input type="text"/>	PN	<input type="text"/>
Pipe material	<input type="text"/>			
Process medium	<input type="text"/>			
Type of medium	<input type="checkbox"/> Liquid	<input type="checkbox"/> Steam	<input type="checkbox"/> Gas	
Flow rate (Q, Q _N , W) ¹⁾	min	standard	max	unit
Temperature at valve inlet T1	<input type="text"/>	<input type="text"/>	<input type="text"/>	<input type="text"/>
Absolute pressure at valve inlet P1	<input type="text"/>	<input type="text"/>	<input type="text"/>	<input type="text"/>
Absolute pressure at valve outlet P2	<input type="text"/>	<input type="text"/>	<input type="text"/>	<input type="text"/>
Steam pressure P _v	<input type="text"/>	<input type="text"/>	<input type="text"/>	<input type="text"/>
Kinematic viscosity (ν)	<input type="text"/>	mm ² /s or cSt		
Dynamic viscosity (η)	<input type="text"/>	mPa.s or cP		
Standard density	<input type="text"/>	Kg/m ³		
Max. sound level accepted	<input type="text"/>	dB (A)		

¹⁾ standard unit: Liquid Q = m³/h; Steam W = kg/h; Gas Q_N = Nm³/h

Valve features

Plug seal material	<input type="checkbox"/> PTFE/stainless steel	<input type="checkbox"/> stainless steel/stainless steel	
Nominal pressure	PN	<input type="text"/>	
Orifice	DN	<input type="text"/>	
Type of connection	<input type="checkbox"/> Threaded	<input type="checkbox"/> Welded	<input type="checkbox"/> Clamp
Standard connection	<input type="checkbox"/> ISO	<input type="checkbox"/> DIN	<input type="checkbox"/> Other <input type="text"/>
Control function	<input type="checkbox"/> NC ²⁾	<input type="checkbox"/> NO ²⁾	
Please specify article no. if known:	<input type="text"/>		

²⁾ NC: normally closed by spring action; NO: normally open by spring action





Comments

* To find your nearest Bürkert facility. click on the orange box → www.burkert.com

Valve system Continuous ELEMENT Type 8802-YG - Request for quotation. continued

Control unit features

For actuator sizes 70/90/130 mm

<input type="checkbox"/> Positioner TopControl Type 8692  <input type="checkbox"/> Process Controller TopControl Type 8693 	<input type="checkbox"/> Positioner TopControl Basic Type 8694 	<input type="checkbox"/> Positioner SideControl Remote Type 8792  <input type="checkbox"/> Process Controller SideControl Remote Typ 8793 
<p>Pneumatic function <input type="checkbox"/> Single-acting <input type="checkbox"/> Double-acting</p> <p>Communication <input type="checkbox"/> Profibus <input type="checkbox"/> DeviceNet</p> <p>Electrical connection <input type="checkbox"/> Cable gland <input type="checkbox"/> Multipol connection</p> <p>Feedback <input type="checkbox"/> 4-20 mA <input type="checkbox"/> 4-20 mA +2 binary outputs</p> <p>Initiator <input type="checkbox"/> Initiator</p> <p>Please specify article no. if known: <input type="text"/></p>	<p>Pneumatic function <input type="checkbox"/> Single-acting</p> <p>Pilot air ports <input type="checkbox"/> Push-in connector external Ø 6 mm or ¼" <input type="checkbox"/> Thread G ⅛"</p> <p>Electrical connection <input type="checkbox"/> Cable gland <input type="checkbox"/> Multipol connection</p> <p>Feedback <input type="checkbox"/> 4-20 mA</p> <p>Please specify article no. if known: <input type="text"/></p>	<p>Power supply 24 V DC</p> <p>Communication <input type="checkbox"/> Without <input type="checkbox"/> Profibus DPV1</p> <p>Feedback <input type="checkbox"/> Analogue feedback + 2 binary outputs <input type="checkbox"/> 2 binary outputs</p> <p>Electrical connection <input type="checkbox"/> Cable gland <input type="checkbox"/> Multipol connection</p> <p>Please specify article no. if known: <input type="text"/></p>

For actuator size 50 mm

<input type="checkbox"/> Positioner TopControl Basic Typ 8696 
<p>Pneumatic function <input type="checkbox"/> Single-acting</p> <p>Pilot air ports <input type="checkbox"/> Push-in connector external Ø 6 mm or ¼" <input type="checkbox"/> Thread G ⅛"</p> <p>Feedback <input type="checkbox"/> 4-20 mA</p> <p>Please specify article no. if known: <input type="text"/></p>

DTS 1000112034 EN Version: R Status: RL (released | freigegeben | valide) printed: 07.02.2018